

wd001326

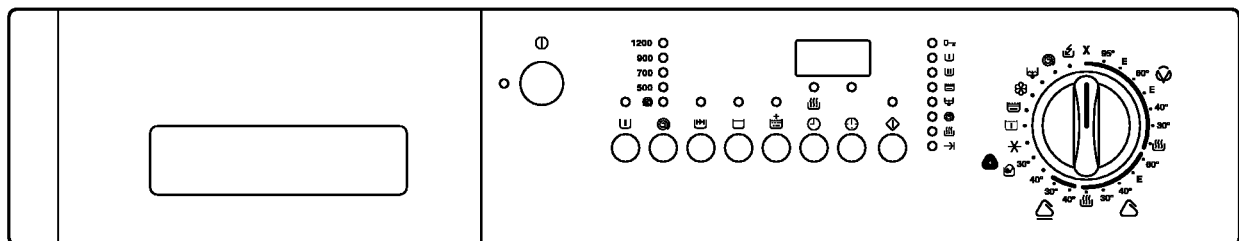

wd001325

ELECTROLUX ZANUSSI S.p.A.
 Corso Lino Zanussi,30
 I - 33080 PORCIA /PN (ITALY)
 Tel +39 0434 394850
 Fax +39 0434 394096

Publication no.

599 34 55-61

EN/SERVICE/EB

TSE-P

Edition: 15.01.2001

**WASHING MACHINES
 &
 WASHER DRYERS
 WITH EWM2000
 ELECTRONIC CONTROL**

Styling:

Multipanel (Built-in)

Production: Porcia/PN (IT)

CONTENTS

GENERAL CHARACTERISTICS	page 3/56
CONTROL PANEL	page 4/56
Control/display board	page 5/56
WASHING PROGRAMMES	page 6/56
Programme selector	page 6/56
Operation of the buttons	page 8/56
Washing cycle options	page 9/56
Buttons	page 10/56
Display	page 14/56
Programme table legend	page 15/56
60° cotton cycle jetsystem	page 17/56
30° wool-handwash cycle jetsystem	page 18/56
60° cotton cycle traditional	page 19/56
30° wool-handwash cycle traditional	page 20/56
Cotton and synthetics drying cycles	page 21/56
"FUCS" (Fast Unbalance Control System)	page 22/56
Spin cycles	page 24/56
TECHNICAL CHARACTERISTICS	page 27/56
EWM2000 electronic control unit	page 27/56
Microprocessor memory	page 28/56
Electronic pressure switch	page 29/56
Instantaneous door safety device	page 30/56
Detergent dispenser	page 31/56
Power supply to motor	page 33/56
AC/DC converter	page 33/56
Recirculation pump	page 34/56
Heating	page 34/56
Drying (washer/dryers only)	page 35/56
DIAGNOSTIC AND CONFIGURATION SYSTEMS	page 37/56
Access to the diagnostics and configuration systems	page 37/56
Diagnostics system	page 38/56
Display board diagnostics	page 38/56
Diagnostics cycle	page 39/56
Programme selector	page 41/56
Alarms	page 42/56
Reading the last alarm	page 43/56
Alarm codes	page 44/56
Cancelling the last alarm condition	page 48/56
Configuration of the main PCB	page 49/56
Configuration codes	page 50/56
Examples of configuration	page 51/56
Exiting the diagnostics/configuration system	page 52/56
Basic circuit diagrams	page 53/56
Notes for the replacement of the control display/board	page 56/56

GENERAL CHARACTERISTICS

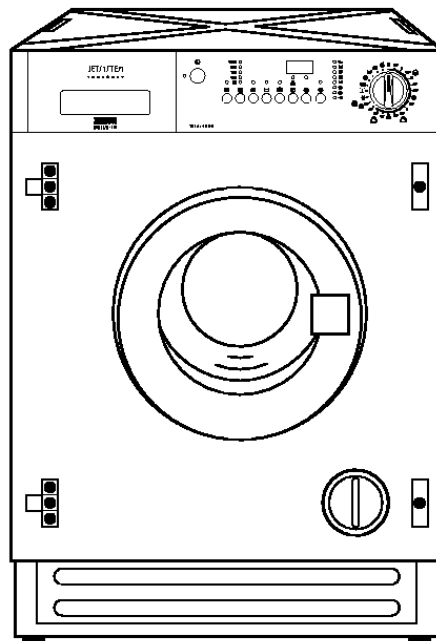

wd001326

Washing machines/washer-dryers with EWM2000 electronic control system:

- electronic pressure switch
- anti-foam control function
- unbalance control system FUCS
- jetsystem or traditional washing system
- "Total exchange" jetsystem or traditional rinse system
- spin speeds up to 1600 rpm
- commutator motor AC or DC with separate converter
- heating element in the tub, 1950W

- water condensation drying system
- automatic or time-controlled drying cycles
- 550 + 550 W drying heater

CONTROL PANEL

The control panel fitted to the appliance may be different depending on:

- ⇒ the control/display board (3 versions)
- ⇒ the programme selector
- ⇒ the different design of the panel (on the number of buttons, LEDs)
- ⇒ the different configuration of the buttons

Control panel example:

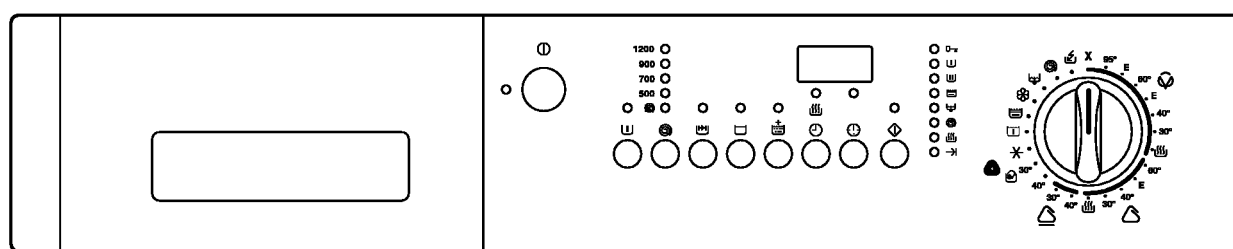

wd001325

GENERAL FEATURES

Programme selector:

- 24, 21 or 12 positions

Main switch:

- bipolar switch

Push-buttons:

- maximum 8, horizontal position

LED:

- maximum 28, green for the wash functions, orange for the drying functions (washer dryers)

Display:

- 3 digits consisting of 24 green LEDs

CONTROL/DISPLAY BOARD

1. Version with display (washing machines and washer/dryers):

⇒ 3 digits

⇒ 28 LEDs

⇒ 8 buttons

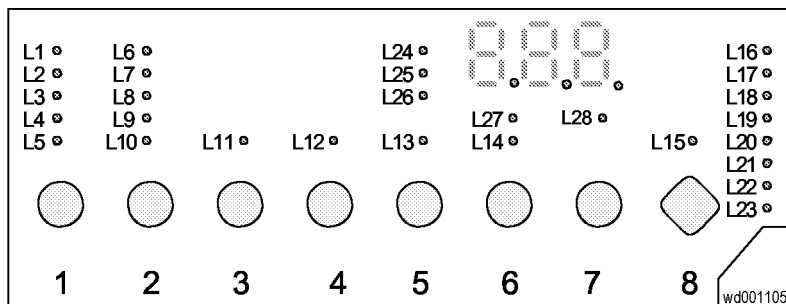

2. Version without display (washing machines):

⇒ 21 LEDs

⇒ 6 buttons

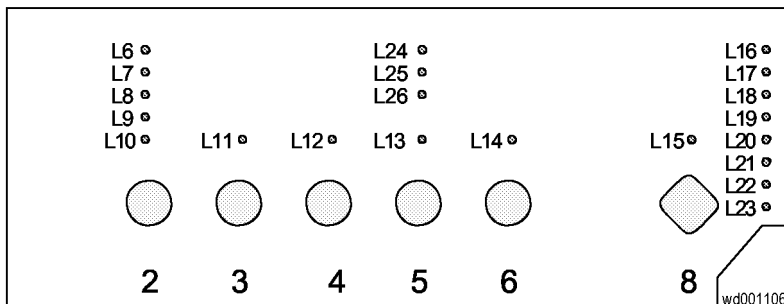

3. Version without display (washing machines):

⇒ 14 LEDs

⇒ 6 buttons

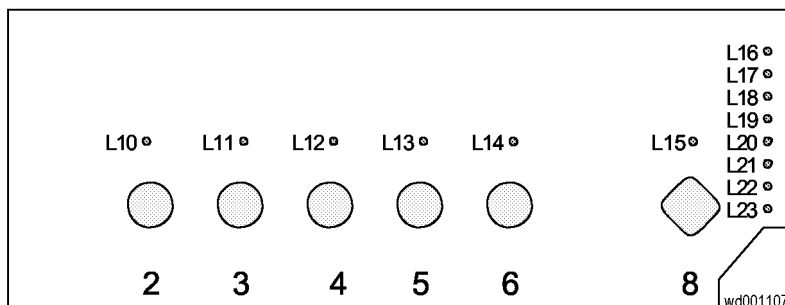

WASHING PROGRAMMES

WASHING PROGRAMMES (24 position selector knob – WM & WD)				
No.	Programme	Temperature	No. of rinses	Spin *
1	CANCEL (RESET)	--	--	--
2	COTTON (WHITE)	90°	3	IMPCF_1
3	COTTON ECO	67°	3	IMPCF_1
4	COTTON (COLOUREDS)	60°	3	IMPCF_1
5	COTTON (COLOUREDS)	50° o 40° Economy	3	IMPCF_1
6	COTTON (COLOUREDS)	40°	3	IMPCF_1
7	COTTON (COLOUREDS)	30°	3	IMPCF_1
8	COTTON	Cold wash (WM) Drying (washer-dryer)	3 --	IMPCF_1 --
9	SYNTHETICS	60°	3	IMP5
10	SYNTHETICS	50° o 40° Economy	3	IMP5
11	SYNTHETICS	40°	3	IMP5
12	SYNTHETICS	30°	3	IMP5
13	SYNTHETICS	Cold wash (WM) Drying (washer-dryer)	3 --	IMP5 --
14	DELICATES	Cold wash	3	IMP7
15	DELICATES	30°	3	IMP7
16	WOOL - HAND WASH	40°	3	IMP4
17	WOOL - HAND WASH	30°	3	IMP4
18	WOOL - HAND WASH	Cold wash	3	IMP4
19	SOAK	40°	--	--
20	RINSES (if spin >700: cotton rinses)	--	3	IMPCF_1
	RINSES (if spin ≤700: delicate rinses)	--	3	IMP7
21	SOFTENER (if spin >700: cotton softener)	--	1	IMPCF_1
	SOFTENER (if spin ≤700: delicate softener)	--	1	IMP7
22	DRAIN	--	--	--
23	SPIN (if spin >700: cotton spin)	--	--	IMPCF_1
	SPIN (if spin ≤700: delicate spin)	--	--	IMP7
24	MINIPROGRAMME	30°	2	IMP7

* see spin cycle chapter

24-position selector knob

The programme selector determines the type of washing cycle (for ex.: water level, drum movement, number of rinses), the washing temperature and enables the drying cycle to be selected according to the laundry.

It is possible to turn the selector knob both clockwise or counterclockwise.

The programme plate is divided into five sections:

- ⇒ Cotton
- ⇒ Synthetics
- ⇒ Delicates
- ⇒ Wool – Hand wash
- ⇒ special cycles (19÷24)

The first position is used to cancel the current cycle.

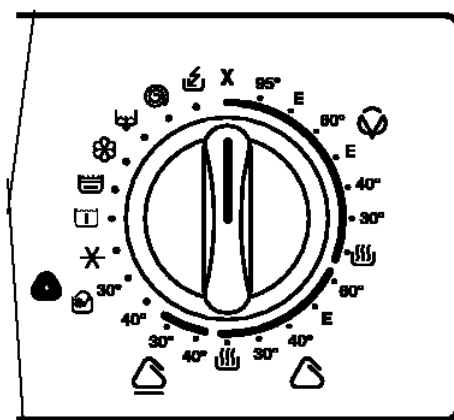

wd001328

WASHING PROGRAMMES (12 position selector knob – WM)				
No.	Programme	Temperature	No. of rinses	Spin *
1	CANCEL (RESET)	--	--	--
2	COTTON (WHITE)	90° ÷ 0°C	3	IMPCF_1
3	COTTON (COLOUREDS)	60° ÷ 0°C	3	IMPCF_1
4	SYNTHETICS	60° ÷ 0°C	3	IMP5
5	DELICATES	40° ÷ 0°C	3	IMP7
6	WOOL	40° ÷ 0°C	3	IMP4
7	HAND WASH	40° ÷ 0°C	3	IMP4
8	SOAK	40° C	--	--
9	RINSES (if spin >700: cotton rinses)	--	3	IMPCF_1
	RINSES (if spin ≤700: delicate rinses)	--	3	IMP7
10	DRAIN	--	--	
11	SPIN (if spin >700: cotton spin)	--	--	IMPCF_1
	SPIN (if spin ≤700: delicate spin)	--	--	IMP7
12	MINIPROGRAMME	60° ÷ 0°C	2	IMP7

WASHING PROGRAMMES (12 position selector knob – WD)				
No.	Programme	Temperature	No. of rinses	Spin *
1	CANCEL (RESET)	--	--	--
2	COTTON	90° ÷ 0°C	3	IMPCF_1
3	COTTON - DRYING	--	--	--
4	SYNTHETICS	60° ÷ 0°C	3	IMP5
5	SYNTHETICS - DRYING	--	--	--
6	DELICATES	40° ÷ 0°C	3	IMP7
7	WOOL	40° ÷ 0°C	3	IMP4
8	HAND WASH	40° ÷ 0°C	3	IMP4
9	SOAK	40° C	--	--
10	RINSES (if spin >700: cotton rinses)	--	3	IMPCF_1
	RINSES (if spin ≤700: delicate rinses)	--	3	IMP7
11	DRAIN	--	--	
12	SPIN (if spin >700: cotton spin)	--	--	IMPCF_1
	SPIN (if spin ≤700: delicate spin)	--	--	IMP7

* see spin cycle chapter

PUSH-BUTTON FUNCTION

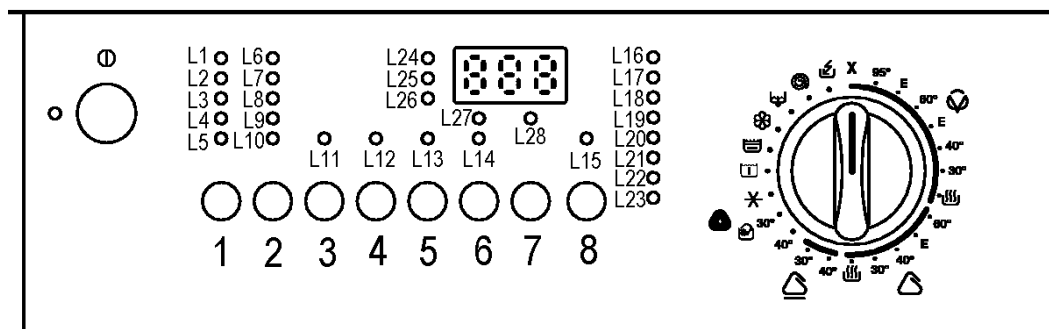

wd001327

The buttons' function can be configured, and therefore it varies according to the model.

Matrix of the function of the different push-buttons:

Button	LED	Function 1	Function 2	Function 3	Function 4	Function 5	Function 6	Function 7
1	L1	Maximum speed	Maximum speed	90°C	Very heavy	90°C	Intensive	--
	L2	900 rpm	900 rpm	60°C	Heavy	60°C	Normal	--
	L3	700 rpm	700 rpm	40°C	Normal	50°C	Quick	--
	L4	500 rpm	500 rpm	30°C	Daily	40°C	--	--
	L5	Rinse hold	No Spin	0°C	Light	30°C	--	Prewash
2	L6	Maximum speed	Maximum speed	90°C	Very heavy	90°C	--	--
	L7	900 rpm	900 rpm	60°C	Heavy	60°C	--	--
	L8	700 rpm	700 rpm	40°C	Normal	50°C	--	--
	L9	500 rpm	500 rpm	30°C	Daily	40°C	Quick	--
3	L10	Rinse hold	Spin speed reduction	0°C	Light	30°C	Prewash	Prewash
	L11	Rinse hold	Spin speed reduction	Intensive	Economy	Stain	Quick	Prewash
4	L12	Rinse hold	Spin speed reduction	Intensive	Economy	Stain	Quick	Extra Rinse
5	L24	--	--	--	Intensive	Delay 8h	Extra Dry	--
	L25	--	--	--	Normal	Delay 4h	Cupboard Dry	--
	L26	--	--	--	Quick	Delay 2h	Iron Dry	--
6	L13	Rinse hold	Spin speed reduction	Intensive	--	--	--	Extra Rinse
	L27	--	--	--	--	--	Drying time	--
	L14	Rinse hold	Spin speed reduction	Intensive	Bio	Half Load	--	Extra Rinse
7	L28	Delayed start	--	--	--	--	--	--
8	L15	Start/Pause	--	--	--	--	--	--

“ON/OFF” button

Press this button to switch the machine on. Press it again to switch the machine off.

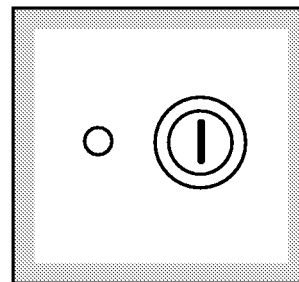

Wd001329

WASHING CYCLE OPTIONS

The washing cycle options should be entered after selecting the desired programme (using the selector knob) and before pressing START/PAUSE.

When the button is pressed, the corresponding LED lights up; by pressing the button again the LED switches off.

Possible options for each programme

OPTIONS	PROGRAMMES									
	Cotton	Synthetics	Delicate	Wool	Mini	Soak	Rinses	Softener	Spin	Drain
95°C	⊗									
Eco	X									
60°C	X	⊗			X					
50° o Eco	X	X			X					
40°C	X	X	⊗	⊗	⊗					
30°C	X	X	X	X	⊗					
Cold (WM)	X	X	X	X	⊗					
Electronic drying	3 levels	1 level								
Time-controlled drying	10÷130 minutes	10÷100 minutes								
>900 rpm	⊗						X	X	X	
900 rpm	X	⊗		⊗			X	X	X	
700 rpm	X	X	⊗	X	X		⊗	⊗	⊗	
500 rpm	X	X	X	X	X		X	X	X	
No spin		X	X	X	X		X	X		
Rinse hold	X	X	X	X	X		X	X		
Prewash	X	X	X							
Stains	X	X	X							
Intensive/Heavy	X	X								
Daily	X	X								
Quick/Light	X	X	X							
Economy	X	X								
Bio	X	X								
Extra rinse	X	X	X				X			
Half Load	X									
Delayed start	X	X	X	X	X	X	X	X	X	X

⊗ = Standard functions X = options

“PREWASH” button

This option selects an additional prewash phase at 30° C at the beginning of the cycle, followed first by a drain phase and then by the next phase. In the COTTON and SYNTHETICS cycles also a short spin phase is performed.

The prewash option cannot be selected for WOOL cycles, nor in conjunction with the STAIN option.

"STAINS" button

The STAINS option can be selected in the COTTON, SYNTHETICS and DELICATES cycles with temperatures of 40°C or higher. This option can be selected only during the programme selection phase, before pressing the START/PAUSE button.

It is used with heavily soiled fabrics or stains; this option adds the STAIN phase, which consists of the introduction of special additives from the prewash compartment after the BIO phase at 40°C, as well as a 10-minute extension of the movement of the motor.

The STAINS option cannot be selected together with the PREWASH, INTENSIVE, and QUICK/DAILY option.

“INTENSIVE” / “HEAVY SOIL” button

This option is available in the COTTON and SYNTHETICS cycles and it increases the duration of the movement of the drum after the heating phases.

This option cannot be selected together with the STAINS, the QUICK /DAILY and the ECO options.

“QUICK” / “LIGHT SOIL” / “DAILY” button

This option can be selected in the COTTON, SYNTHETICS and DELICATES cycles, and can also be selected while the appliance is in "PAUSE" mode. This option reduces the duration of the cycle.

In COTTON cycles, one of the rinses is eliminated; the water level in the other rinses is increased.

This option cannot be selected together with the STAINS, INTENSIVE or ECO options.

“LEVEL OF SOILING” button

This option can be selected at any time during the washing programme (after pressing "PAUSE").

The standard programme is set for NORMAL soiling; by pressing this button, the user can modify this setting to INTENSIVE/HEAVY SOIL or LIGHT SOIL/DAILY.

“BIO” button

This option is available in the COTTON and SYNTHETICS cycles with temperatures equal to or higher than 40°C, and can be selected only during the programme selection phase.

The BIO option adds a 10-minute drum movement phase after the 40°C heating phase in order to activate the enzymes contained in the detergent

“HALF LOAD” button

This option can be selected in the COTTON cycles on traditional (i.e. non-Jetsystem) washing machines, and reduces the number of rinse cycles by one.

“EXTRA RINSE” button

Can be used with all programmes **except the wool programme**. The machine performs 4 rinses instead of 3.

This option is recommended for people who are allergic to detergents and in areas where the water is very soft.

“RINSE HOLD” button

When this option is selected the cycle ends leaving water in the tub after the final rinse to prevent fabrics from creasing.

In the RINSE HOLD phase, the final spin speed can be modified; press the START/PAUSE button to complete the cycle, or select a new drain or spin programme. In this case turn the knob on the CANCEL position, before the new programme is selected.

In the case of washer-dryers, this option can not be selected, if the drying phase at the end of the cycle has already been selected.

If the drain phase has not been performed after 18 hours, the programme ends automatically.

“SPIN SPEED” button

When this button is pressed, the speed of the intermediate and final spin phases is modified as shown in the table below. The maximum speed in the COTTON cycles depends on the models. It is 900 rpm in the SYNTHETIC and WOOL/HANDWASH cycles and 700 rpm in the DELICATES cycle.

If automatic drying has already been selected (washer-dryers only), the minimum spin speed is 900 rpm for COTTON and 700 rpm for SYNTHETICS.

The configuration of this button varies according to the model:

Maximum speed (rpm)	Level 1 (rpm)	Level 2 (rpm)	Level 3 (rpm)	Level 4
1600 (washing machines)	900	700	500	No spin or Rinse hold
1600 (washer-dryers)	1200	900	700	
1500 (washing machines)	900	700	500	
1500 (washer-dryers)	1200	900	700	
1400 (washing machines)	900	700	500	
1400 (washer-dryers)	1200	900	700	
1300	900	700	500	
1200	900	700	500	
1100	900	700	500	
1000	900	700	500	
900	---	700	500	

In COTTON cycles, this option also modifies the structure of the rinsing phases according to the speed of the intermediate spin:

Intermediate spin (rpm)	Traditional washing			Jetsystem washing		
	1 st rinse	2 nd rinse	Last rinse	1 st rinse	2 nd rinse	Last rinse
<850	TR2	TR2	TR2	TR2	TR2	TR2
850-950	TR1	TR2	TR2	TE	TR2	TR2
1000-1150	TR1	TR1	TR2	TE	TE	TR2
>1150	TR1	TR1	TR1	TE	TE	TE

TR2 Traditional rinse at second level

TR1 Traditional rinse at first level

TE "total exchange" (virtual tank) jetsystem rinse

In the RINSE and SPIN special programmes, this button reduces not only the spin speed but it also modifies the spin structure:

⇒ for spin phases superior to 700 rpm, the spin cycle corresponds to the COTTON spin cycles.

⇒ for spin phases superior to 700 rpm, the spin cycle corresponds to the DELICATES spin cycles.

“REDUCED SPIN SPEED” button

When this button is pressed, the speed of the final spin in COTTON cycles is reduced to 650 rpm.; in the SYNTHETICS, DELICATES and WOOL cycles it is reduced to 500 rpm.
When the RINSE or SPIN cycles are selected, the spin structure changes from the COTTON to the DELICATES spin.

“DELAYED START” button

Models with digit: This button can be used during the programme selection phase to enter a delayed start time (from 1 to 24 hours). During the delayed start countdown, the time decreases at intervals of one hour.

Models with led: This button can be used during the programme selection phase to enter a delayed start time of 2, 4 or 8 hours. During the delayed start countdown, the LEDs switch off according to the time to elapse.

“NO BUZZER” option

On models provided with buzzer, it is possible to disactivate the sound which indicates the end of the cycle.

Press simultaneously pause button and no. 6 (or 5) button to disactivate the buzzer; this option is memorised as long as it will not be disactivated through the same procedure.
In case of an alarm condition the buzzer will be active.

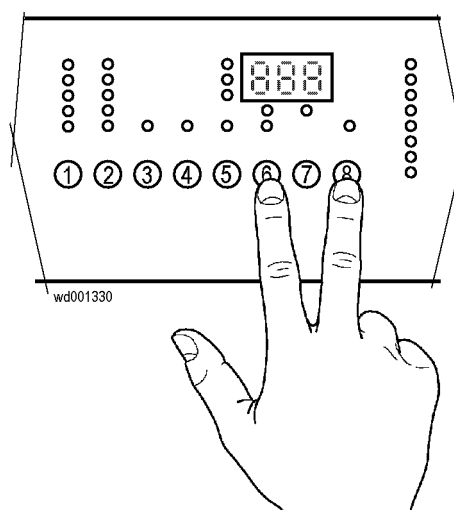

“TEMPERATURE” button (only for appliances with the 12-position programme selector)

When this button is pressed, the temperature for the cycle is modified according to the configuration of the button.
The TEMPERATURE button is operative only after selecting the type of fabric; the temperature may be modified up to the end of the washing cycle (after pressing PAUSE).

Type A	Type B
90°C	90°C
60°C	60°C
40°C	50°C
30°C	40°C
0°C	30°C

“ECONOMY” button (only for appliances with the 12-position programme selector)

This option is available in the COTTON and SYNTHETICS cycles with temperatures higher than 40°C. The ECO option can be selected only during the programme selection phase.
It reduces the temperature of the water during the programme and increases the drum movement phases after the heating phases.
This option cannot be selected together with the INTENSIVE or QUICK/DAILY options.

“ELECTRONIC DRYING” button (WASHER-DRYERS, certain models only)

It is possible to select two different electronic levels of dryness: one for COTTON and one for SYNTHETICS cycles:

⇒ Extra dry (only cotton)

⇒ Store dry (cotton and synthetics)

⇒ Iron dry (only cotton)

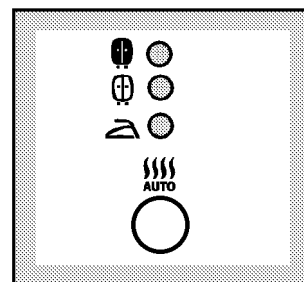

wd001128

The drying time is automatically calculated by the "Fuzzy" logic.

The drying phase can be performed either as automatic drying phase (non stop programme), if previously selected together with the washing programme, as well as a separate drying phase.

“DRYING TIME” button (WASHER-DRYERS)

When this button is pressed it is possible to select (5 minutes a time) from 10 to 130 minutes drying for COTTON cycles and from 10 to 100 minutes for SYNTHETICS cycles.

The drying cycle can be selected both as automatic drying and as separate drying cycle.

“START/PAUSE” button

Start: After entering the parameters for the cycle, press this button to start the wash programme; the corresponding pilot light stops flashing. If the DELAYED START button has been pressed, the delayed start countdown is shown up in the display.

Pause: When the button is pressed again, the current programme is interrupted and the display, or relative LED, flashes. When the appliance is in “pause” mode the door can be opened provided that:

- the appliance is not in the heating or drying phase
- the water level is not high
- there is no movement of the drum

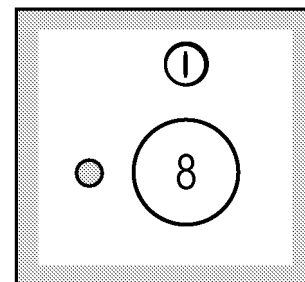

wd001331

When in “pause” mode, some of the programme parameters can be modified:

- all cycle options can be modified prior to the phase in which they are performed
- the spin speed can be modified before the final spin
- drying selections can be modified before the starting of the drying phase.

To re-start the cycle, press the START/PAUSE button.

Water drain and spin cycle: after the "rinse hold" phase press this button to start the cycle with the drain and final spin again.

DISPLAY

The display shows the following information:

- ⇒ **three flashing lights**, when the appliance is switched on.
- ⇒ **the wash programme duration**; it is shown up after the programme has been selected. The time corresponding to the maximum wash load is shown up. While performing the cycle, the time decreases (updated) every minute.
- ⇒ **the drying programme duration (washer-dryers)**, which is displayed during the phase of selection of the drying time. After two seconds the total time corresponding to half wash load is shown up. In non-stop cycles the time results from the wash plus drying time.
- ⇒ **the programme end** indicated by a "0" (when it is possible to open the door).
- ⇒ **the delayed start**, selected through the relative button. After the START/PAUSE button has been pressed, the countdown begins and the time decreases every hour.
- ⇒ **an alarm code**, in case of a malfunction.

PROGRAMME PHASE LEEDS

During the selection of the programme, the LEDs relative to the different phases of the programme light up.

When the cycle starts only the LED corresponding to the current phase lights.

The programme end LED switches on when the programme ends. The "overdosing" LED switches on at the end of the cycle if, during the programme, foam is detected caused by an excessive detergent addition (in some cases the cause might be an obstructed drain hose).

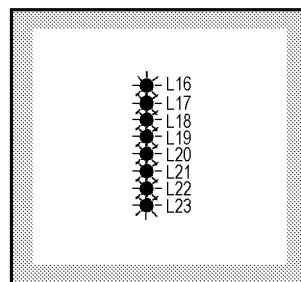

wd001232

LED function according to the type of appliance:

LED	LED colour	Without door indication LED		With door indication LED	
		Washing machines	Washer-dryers	Washing machines	Washer-dryers
L16	Green	Prewash	Prewash	Door	Door
L17	Green	Wash	Wash	Prewash	Prewash
L18	Green	Rinse	Rinse	Wash	Wash
L19	Green	Rinse Hold	Rinse Hold	Rinse	Rinse
L20	Green	Drain	Drain	Drain	Drain
L21	Green	Spin	Spin	Spin	Spin
L22	Orange	Filter Clogged	Drying	Filter Clogged	Drying
L23	Green	End/alarm	End	End/alarm	End

WASHING PROGRAMMES (SEQUENCE CHARTS)

KEY TO PROGRAMMES	
Description	
Calibration	Drain sub-phase for calibration of the electronic pressure switch
Levels	
WC	Level of water in the tub
RPC	Control level for circulation pump
DPC	Control level for drain pump
MC	Control level for motor
Pumps	
OFF	Pump off
ON	Pump on
LEV	Pump on from one level of pressure switch
Water inlet valves	
ELV2	Prewash
ELV3	Wash
ELV2 ELV3	Prewash + wash = softener
Refilling	
NR	Normal refilling
VT	"Total exchange" refilling (virtual tank)
WL	Electronic pressure switch
AB	Safety pressure switch
Dis	Level control disabled
En	Level control enabled
Movement (motor)	
OFF	Motor stopped
ON	Motor in operation
LEV	Level movement
Tempo	
Tout	Maximum time (timeout)
Drying	
TMP	It is active up to the selected temperature

Motor movement			
Code	Pause (sec)	Movement (sec)	Speed (rpm)
D_MOV	12	4	55
E_MOV	3	10	55
E1_MOV	4	12	75
SE_MOV	4	24	55/40
N_MOV	8	8	55
PWL1_MOV	40	1	35
PWL3_MOV	12	1	35
PWL4_MOV	57	1	35
COLD_MOV	4	12	40
CR3_MOV	Single-direction movement		80
DLD_MOV	Single-direction movement		40
DRY_MOV	57	3	55

SE Movement:

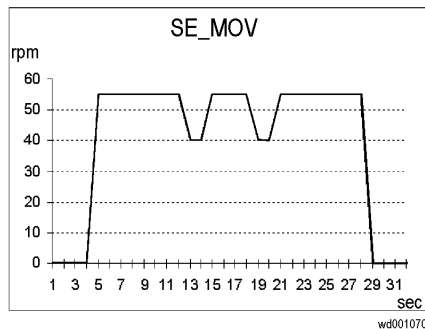

VT movement during rinses in "jetsystem total exchange" COTTON programmes (virtual tank):

During these phases, in which the motor rotates at high speed, if the electronic pressure switch detects that the water in the tub falls below a certain level, the following operations are performed:

spin at 470 rpm (VT_MOV_CODE) to remove the water from the fabrics and therefore to increase the level in the tub.

5 seconds pause, during which the level is again checked and, if necessary, the solenoid valve is activated in order to load water until the level is correct.

energetic movement (E) (with the circulation pump in operation).

These operations may be repeated up to a maximum of three times for each rinse.

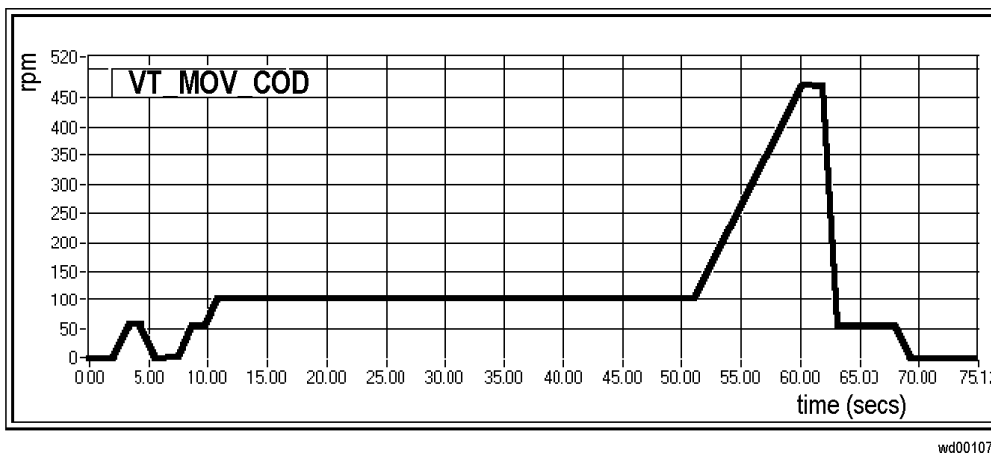

The parameters of the different programmes (levels, movements) vary according to the wash system of the different models:

jetsystem (with circulation pump)

traditional

Cotton 60 JETSYSTEM (G46L Intermediate spin 850-1000)

Step n.°	PHASE	Description	Levels (mm H2O)					Rec. pump	Drain pump	Eiv / Det comp.	Movement		Refilling		Temp. °C	Time	Time to end
			wc	rpc	dpc	mc					type	code	type	wl			
1	WASH	CALIBRATION	35/15	35/15	35/15	35/15	OFF	ON	ELV2	OFF	Motor Stopped	NR	Dis	Dis		Tout 10'	0.00.20
2		WATER LOAD	40/15					OFF	ELV2	ON	PWL3_MOV		En			Tout 15'	0.01.40
3		MOVEMENT														1'	0.01.00
4		WATER LOAD	70/30					LEV	ELV3	ON	DLD_MOV					Tout 15'	0.01.40
5		MOVEMENT	60/40					OFF		LEV	COLD_MOV					4'	0.04.00
6		MOVEMENT						OFF			E_MOV					3'	0.03.00
7		HEATING	35/15					OFF							En	Tout 40'	0.08.50
8		HEAT+MOV						OFF		ON					En	Tout 2'	0.02.00
9		HEATING						ON		LEV					En	Tout 40'	0.06.50
10		MOVEMENT						ON		ON					Dis	Tout 2'	0.02.00
11		HEAT+MOV						OFF							En	Tout 2'	0.02.00
12		HEATING						ON		LEV					En	Tout 40'	0.01.10
13		MOVEMENT						ON		ON	SE_MOV				Dis	Tout 12'	0.12.00
14		MOVEMENT									N_MOV					4'	0.04.00
15		MOVEMENT									SE_MOV					14'	0.14.00
16		MOVEMENT						OFF		OFF	Motor Stopped					22"	0.00.20
17		WATER DRAIN						ON		ON	D_MOV					Tout 10'	0.00.20
18		SPINNING						ON			IMP6					Tout 20'	0.09.00
19	1st RINSE	MOVEMENT						OFF		ON	CR3_MOV					5"	0.00.10
20		WATER LOAD	75/20					LEV							En	Tout 15'	0.01.40
21		MOVEMENT	35/25								E_MOV	VT				5'	0.05.00
22		MOVEMENT									E1_MOV	NR	Dis			3'	0.03.00
23		WATER DRAIN						OFF		Lev	D_MOV					Tout 10'	0.00.20
24		SPINNING						ON		ON	IMP6_RINSE					Tout 20'	0.05.00
25	2nd RINSE	MOVEMENT	35/15					OFF			CR3_MOV					5"	0.00.10
26		WATER LOAD	75/20					LEV							En	Tout 15'	0.01.40
27		MOVEMENT						ON			E_MOV	VT				5'	0.05.00
28		MOVEMENT									E1_MOV	NR	Dis			3'	0.03.00
29		WATER DRAIN						OFF		Lev	D_MOV					Tout 10'	0.00.20
30		SPINNING						ON		ON	IMP6_RINSE					Tout 20'	0.05.00
31	3rd RINSE	MOVEMENT	35/15					OFF			CR3_MOV					5"	0.00.10
32	(softener)	WATER LOAD	95/20					LEV			N_MOV				En	Tout 15'	0.01.40
33		MOVEMENT														14'	0.11.00
34		MOVEMENT						OFF		OFF	Motor Stopped					22"	0.00.20
35	SPINNING	WATER DRAIN	35/15					Lev		ON	D_MOV					Tout 10'	0.00.20
36		SPINNING						ON			IMPCF_01_AC					Tout 20'	0.20.00
37		MOVEMENT						OFF			N_MOV					2'	0.02.00

Handwash 30 JETSYSTEM G46L

Step n.°	Phase	Description	Levels (mm H2O)					Rec. pump	Drain pump	Elv / Det comp.	Movement		Refilling		Temp. °C	Time	Time to end
			wc	rpc	dpc	mc					type	code	type	wl			
1	WASH	CALIBRATION	35/15	35/15	35/15	35/15	OFF	ON	ELV2	OFF	Motor Stopped	NR	Dis	Dis		Tout 10'	0.00.00
2		WATER LOAD	40/15					OFF	ELV2	ON	PWL3_MOV		En			Tout 15'	0.01.10
3		MOVEMENT													1'	0.01.00	
4		WATER LOAD	115/50				LEV		ELV3	OFF	Motor Stopped				Tout 15'	0.01.10	
5		MOVEMENT								LEV	PWL1_MOV				4'	0.04.00	
6		HEATING					ON							En	Tout 40'	0.06.20	
7		MOVEMENT					LEV								2'	0.02.00	
8		HEAT+MOV												30	14'	0.14.00	
9		MOVEMENT					OFF			OFF	Motor Stopped		Dis	Dis	22"	0.00.20	
10		WATER DRAIN						Lev							Tout 10'	0.00.20	
11		TIME WATER DRAIN						ON							1'	0.01.30	
12	1st RINSE	MOVEMENT	35/15					OFF		OFF	Motor Stopped				5"	0.00.10	
13		WATER LOAD	160/80				LEV			ON	PWL3_MOV		En		Tout 15'	0.01.10	
14		MOVEMENT								ON	PWL1_MOV				3'	0.03.00	
15		WATER DRAIN					OFF	Lev		OFF	Motor Stopped		Dis		Tout 10'	0.00.20	
16		TIME WATER DRAIN						ON							1'	0.01.30	
17	2nd RINSE	MOVEMENT	35/15					OFF		OFF	Motor Stopped				5"	0.00.10	
18		WATER LOAD	160/80				LEV			ON	PWL1_MOV		En		Tout 15'	0.01.10	
19		MOVEMENT								ON	PWL1_MOV				3'	0.03.00	
20		WATER DRAIN						Lev		OFF	Motor Stopped		Dis		Tout 10'	0.00.20	
21		TIME WATER DRAIN						ON							1'	0.01.30	
22	3rd RINSE	MOVEMENT	35/15					OFF		OFF	Motor Stopped				5"	0.00.10	
23	(softener)	WATER LOAD	160/80				LEV		ELV2 ELV3	OFF	Motor Stopped		En		Tout 15'	0.01.10	
24		MOVEMENT								ON	PWL1_MOV				5'	0.05.00	
25		MOVEMENT					OFF			OFF	Motor Stopped		Dis		22"	0.00.20	
26	SPINNING	WATER DRAIN	35/15					Lev		OFF	Motor Stopped				Tout 10'	0.00.20	
27		SPINNING						ON		ON	IMP4				Tout 20'	0.14.20	

Cotton 60 TRADITIONAL (G46L Intermediate spin 850 10000)

Step n.°	PHASE	Description	Levels			Drain pump	Eiv / Det comp.	Movement		Refilling			Temp. °C	Time	Time to end
			wc	dpc	mc			type	code	type	wl	ab			
1	WASH	CALIBRATION	40/15	40/15	40/15	ON	ELV2	OFF	Motor Stopped	NR	Dis	Dis		Tout 10'	0.00.20
2		WATER LOAD				OFF	ELV2				En			Tout 15'	0.01.40
3		MOVEMENT						ON	PWL3_MOV					1'	0.01.00
4		MOVEMENT												1"	0.00.00
5		WATER LOAD	95/65				ELV3	OFF	Motor Stopped					Tout 15'	0.01.40
6		MOVEMENT			95/65			LEV	COLD_MOV					4'	0.04.00
7		MOVEMENT							E_MOV					3'	0.03.00
8		HEATING									En		40	Tout 40'	0.12.10
9		HEATING						LEV	N_MOV		En	En	56	Tout 40'	0.12.00
10		MOVEMENT						ON	SE_MOV		Dis	Dis		6'	0.06.00
11		MOVEMENT							E_MOV					8'	0.08.00
12		MOVEMENT							N_MOV					4'	0.04.00
13		MOVEMENT							SE_MOV					18'	0.18.00
14		MOVEMENT							PWL3_MOV					4'	0.04.00
15		WATER DRAIN				Lev			D_MOV					Tout 10'	0.00.20
16		SPINNING				ON			IMP6					Tout 20'	0.09.00
17	1st RINSE	MOVEMENT	40/15		40/15	OFF		OFF	Motor Stopped					6"	0.00.10
18		WATER LOAD	125/70								En			Tout 15'	0.01.40
19		MOVEMENT			125/70			LEV	E_MOV					5'	0.05.00
20		WATER DRAIN				Lev		ON	D_MOV		Dis			Tout 10'	0.00.20
21		SPINNING				ON			IMP6_RINSE					Tout 20'	0.05.00
22	2nd RINSE (softener)	MOVEMENT	40/15		40/15	OFF		OFF	Motor Stopped		En			Tout 15'	0.01.40
23		WATER LOAD	125/70								En			5'	0.05.00
24		MOVEMENT			125/70			LEV	E_MOV					Tout 10'	0.00.20
25		WATER DRAIN				Lev		ON	D_MOV		Dis			Tout 20'	0.05.00
26		SPINNING				ON			IMP6_RINSE					Tout 20'	0.00.10
27	3rd RINSE	MOVEMENT	40/15		40/15	OFF		OFF	Motor Stopped		En			Tout 15'	0.01.40
28		WATER LOAD	145/90				ELV2 ELV3							7'	0.07.00
29		MOVEMENT			145/90			LEV	N_MOV					22"	0.00.20
30		MOVEMENT						OFF	Motor Stopped		Dis			Tout 10'	0.00.20
31	SPINNING	WATER DRAIN	40/15		40/15	Lev		ON	D_MOV					Tout 20'	0.20.00
32		SPINNING				ON			IMPCF_01_AC					Tout 20'	0.02.00
33		MOVEMENT				OFF			N_MOV					2'	0.02.00

Handwash 30 TRADITIONAL

Step n.°	PHASE	Description	Levels (mm H2O)			Drain pump	Elev / Det comp.	Movement		Refilling			Temp. °C	Time	Time to end
			wc	dpc	mc			type	code	type	wl	ab			
1	WASH	CALIBRATION	40/15	40/15	40/15	ON	ELV2	OFF	Motor Stopped	NR	Dis	Dis		Tout 10'	0.00.00
2		WATER LOAD				OFF	ELV2				En			Tout 15'	0.01.10
3		MOVEMENT						ON	PWL3_MOV					1'	0.01.00
4		WATER LOAD	150/80				ELV3	OFF	Motor Stopped					Tout 15'	0.01.10
5		MOVEMENT						LEV	PWL1_MOV					4'	0.04.00
6		HEATING									En		30	Tout 40'	0.05.00
7		MOVEMENT												2'	0.02.00
8		HEAT+MOV											30	14'	0.14.00
9		MOVEMENT						OFF	Motor Stopped		Dis	Dis		22"	0.00.20
10		WATER DRAIN				Lev								Tout 10'	0.00.20
11		TIME WATER DRAIN				ON								1'	0.01.30
12	1st RINSE	MOVEMENT	40/15			OFF		OFF	Motor Stopped					6"	0.00.10
13		WATER LOAD	153/110								En			Tout 15'	0.01.10
14		MOVEMENT						ON	PWL3_MOV					3'	0.03.00
15		WATER DRAIN				Lev		OFF	Motor Stopped		Dis			Tout 10'	0.00.20
16		TIME WATER DRAIN				ON								1'	0.01.30
17	2nd RINSE	MOVEMENT	40/15			OFF		OFF	Motor Stopped					6"	0.00.10
18		WATER LOAD	153/110								En			Tout 15'	0.01.10
19		MOVEMENT						ON	PWL1_MOV					3'	0.03.00
20		WATER DRAIN				Lev		OFF	Motor Stopped		Dis			Tout 10'	0.00.20
21		TIME WATER DRAIN				ON								1'	0.01.30
22	3dr RINSE	MOVEMENT	40/15			OFF		OFF	Motor Stopped					6"	0.00.10
23	(softener)	WATER LOAD	153/110				ELV2 ELV3				En			Tout 15'	0.01.10
24		MOVEMENT						ON	PWL1_MOV					5'	0.05.00
25		MOVEMENT						OFF	Motor Stopped		Dis			22"	0.00.20
26	SPINNING	WATER DRAIN	40/15			Lev		OFF	Motor Stopped					Tout 10'	0.00.20
27		SPINNING				ON		ON	IMP4					Tout 20'	0.14.20

Cotton IRON DRYING

step n	Option	Description	Levels		Power	Condensation valve	Drain pump	Fan	Movement		Time	Time to end
			WC						Type	Code		
1		CALIBRATION		10/0	OFF	OFF	ON	OFF	ON	N_MOV	Tout 10'	0.00.00
2		TAP_TEST					OFF				Tout 10'	0.00.00
3	if AUTODRY:	FABRIC DETACH				TMP	ON	TMP			Tout 10'	0.10.00
4	if T>35°C	FIRST COOL DOWN									Tout 20'	0.00.00
5		DRY_Acq			FULL	ON		ON		DRY_MOV	Tout 20'	0.16.00
6		TIME DRY			FULL						72'	1.12.00
7		COOL DOWN			OFF						Tout 10'	0.10.00

Synthetics STORE DRY

step n	Option	Description	Levels		Power	Condensation valve	Drain pump	Fan	Movement		Time	Time to end
			WC						Type	Code		
1		CALIBRATION			OFF	OFF	ON	OFF			Tout 10'	0.00.00
2		TAP_TEST		10/0			OFF		ON	N_MOV	Tout 10'	0.00.00
3	if T>35°C:	FIRST COOL DOWN				TMP	ON	TMP			Tout 20'	0.00.00
4		DRY_Acq			HALF	ON		ON		DRY_MOV	Tout 20'	0.16.00
5		TIME DRY									84'	1.24.00
6		COOL DOWN			OFF						Tout 10'	0.10.00

“FUCS” (Fast Unbalance Control System)

The control procedure for unbalanced loads is performed dynamically, before each spin cycle, as follows:

The phase begins at a speed of 55 rpm; the speed can never fall below this threshold, otherwise the check is repeated.

At intervals of 400 ms, the balance is calculated and compared with predetermined limits. If the value is less than the lower limit, the speed of the drum is increased by 2 rpm; if the value is higher, the speed of the drum is reduced by 2 rpm. The reduction in the speed of the drum distributes the washing correctly; this procedure is repeated until the wash load is completely balanced.

Correct balancing of the wash load is achieved at a speed of 115 rpm, after which the spin cycle begins.

The Unbalancing Control function takes place in three steps:

Step 1: The first phase has a preset unbalancing threshold: if correct balancing is achieved, the appliance performs the spin cycle. If not, after a maximum of 60 seconds, a spin pulse at 470 rpm is performed and the function passes to step 2.

Step 2: In the second phase, the unbalancing threshold is variable: if correct balancing is not achieved within 180 seconds, the function passes to step 3.

Step 3: The third phase has a preset unbalancing threshold: if correct balancing is not achieved within 60 seconds, the spin cycle is performed at a lower speed. In this case, spinning may also start at 85 rpm.

If the unbalancing value remains excessive, the spin cycle is skipped.

Anti-foam control function

If the pressure switch detects an anti-foam level (i.e. excessive foam) at the beginning of the spin cycle, the spin is interrupted and the appliance resumes operation from the second phase of the unbalancing control procedure.

EXAMPLES OF OPERATION OF THE UNBALANCING CONTROL FUNCTION:

Load correctly balanced

- A: low speed
- B: FUCS phase 1
- C: normal spin

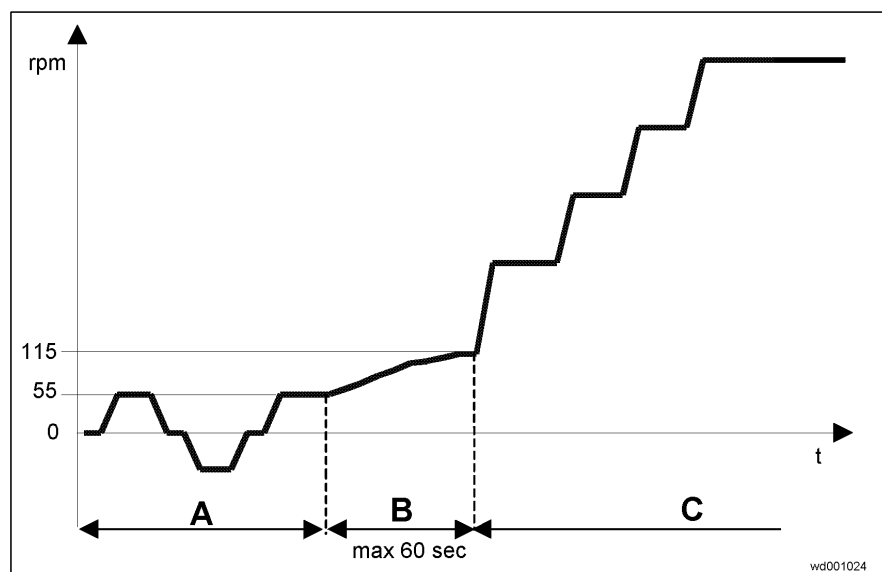

Load balanced after few attempts:

- A: low speed
- B: FUCS phase 1
- C: normal spin

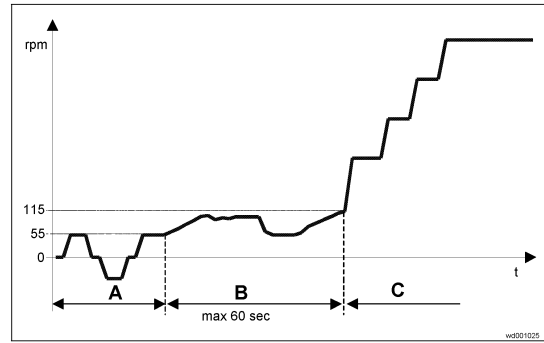

Load balanced after second phase:

- A: low speed
- B: FUCS phase 1 with pulse at 470 rpm
- C: low speed
- D: FUCS phase 2
- E: normal spin

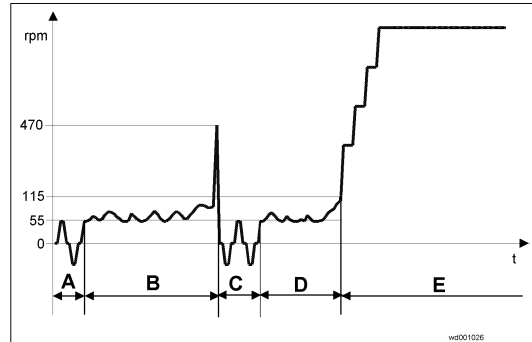

Load balanced after second phase and anti-foam control function:

- A: low speed
- B: FUCS phase 1 with pulse at 470 rpm
- C: low speed
- D: FUCS phase 2
- E: spin with anti-foam function
- F: low speed
- G: FUCS phase 3
- H: normal spin

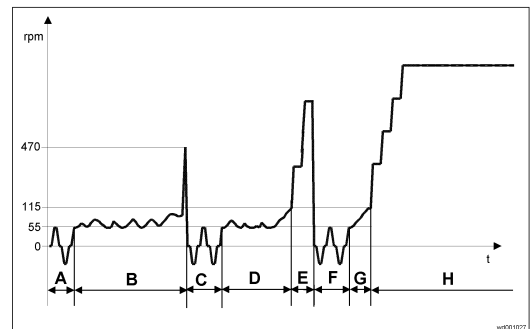

Load slightly unbalanced after third phase:

- A: low speed
- B: FUCS phase 1 with pulse at 470 rpm
- C: low speed
- D: FUCS phase 2
- E: FUCS phase 3
- F: reduced-speed spin

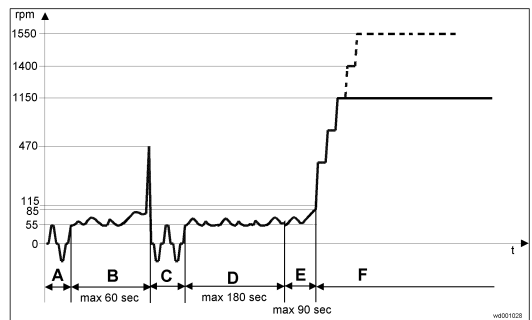

Load unbalanced after third phase:

- A: low speed
- B: FUCS phase 1 with pulse at 470 rpm
- C: low speed
- D: FUCS phase 2
- E: FUCS phase 3
- F: the spin phase is skipped and the appliance passes to the subsequent phase

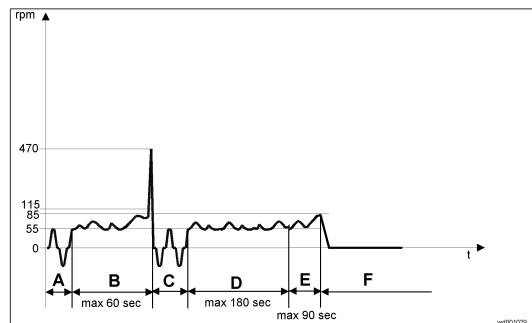

SPIN CYCLES

IMP_C0 spin: pre-wash - COTTONS and SYNTHETICS, penultimate rinse - SYNTHETICS

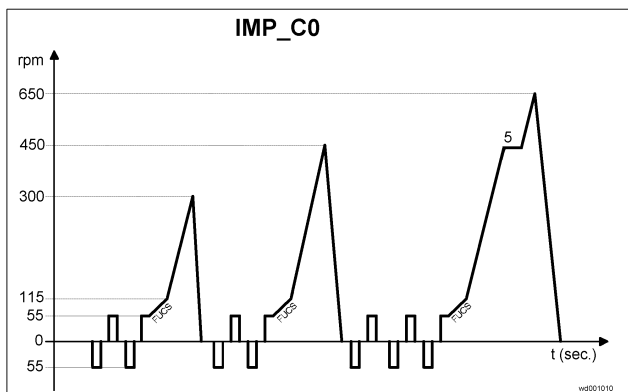

IMP5 spin: final - SYNTHETICS

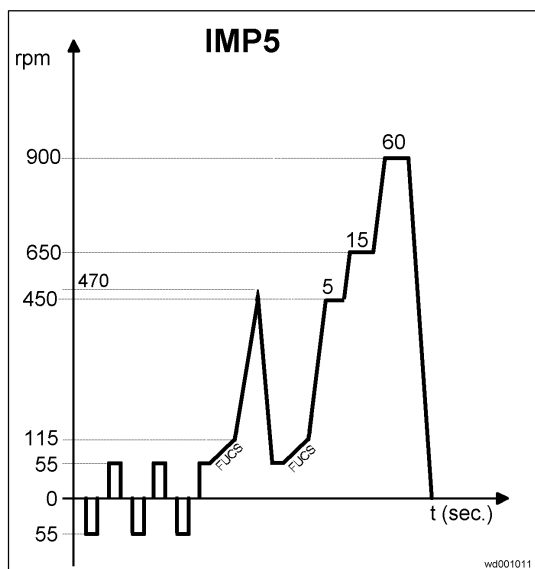

IMP7 spin: final - DELICATE FABRICS

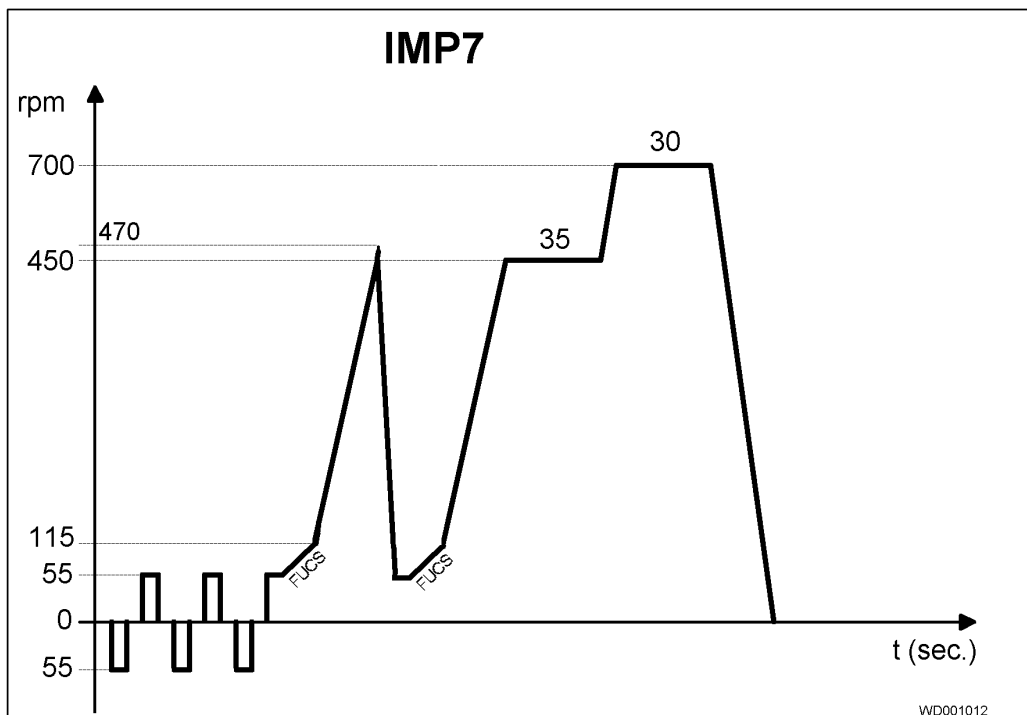

IMP4 spin: final - WOOL

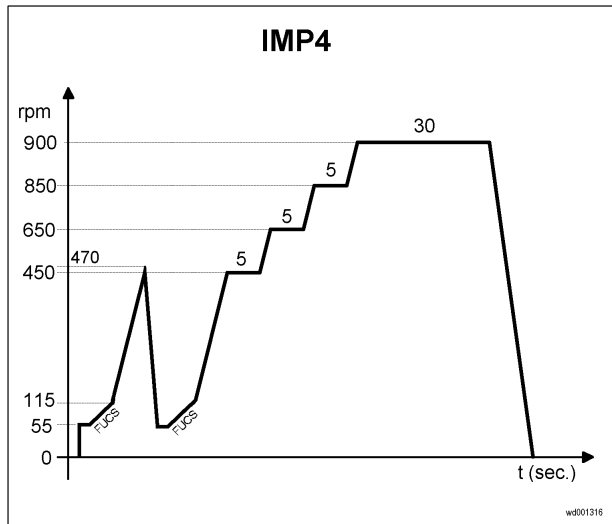

IMP6 spin: first intermediate spin - rinses – COTTON (maximum speed can be configured)

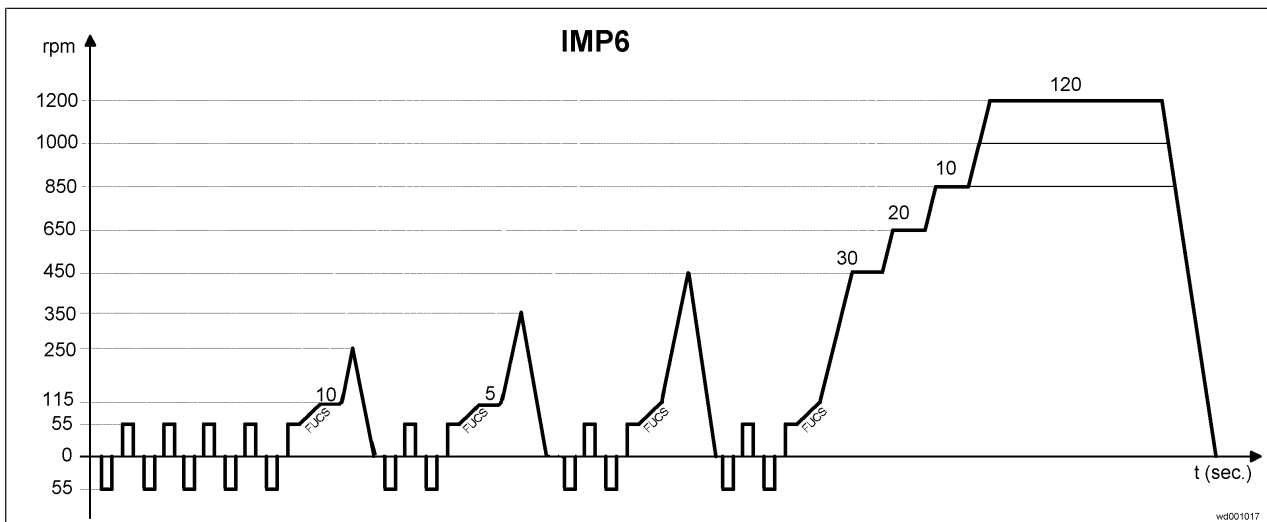

IMP6-RINSE spin: intermediate rinses COTTON (maximum speed can be configured)

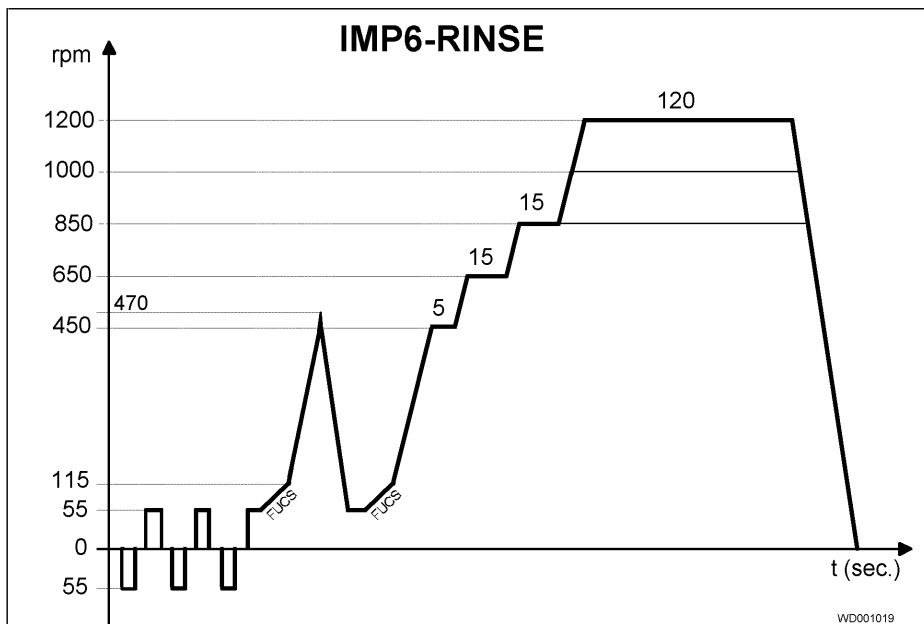

IMPCF_1_AC spin: final – COTTON (AC motors)

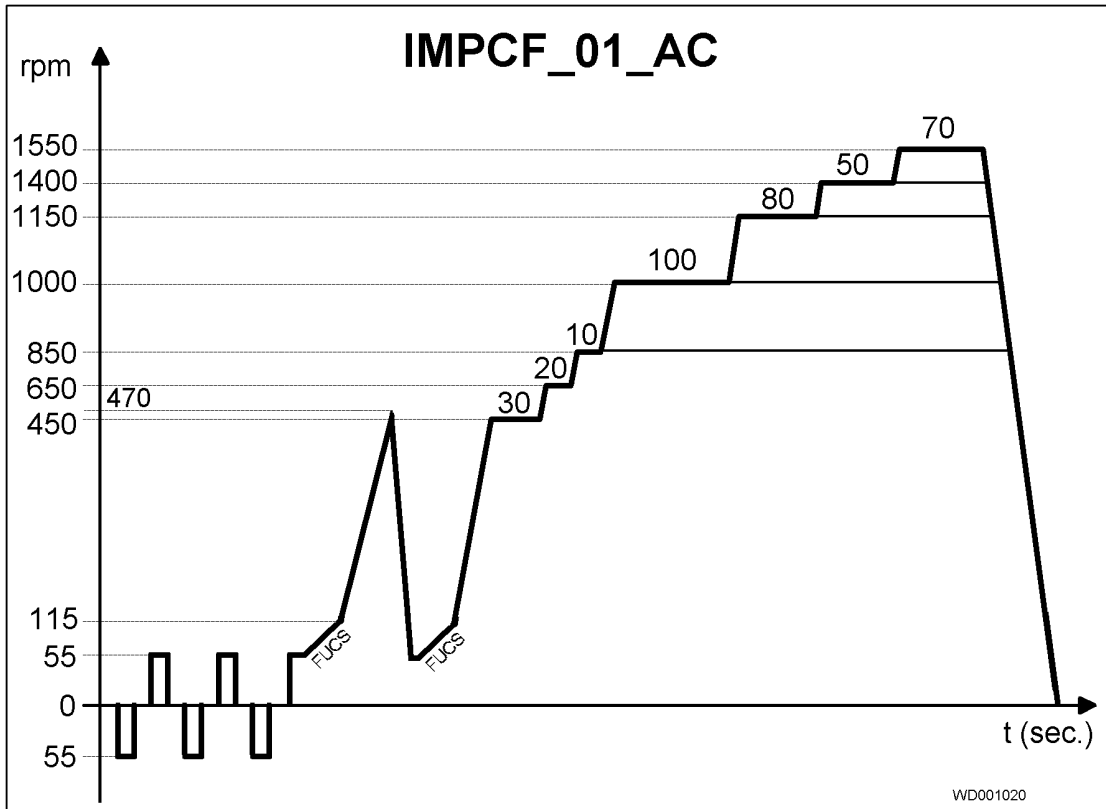

IMPCF_1_AC spin: final – COTTON (DC motors)

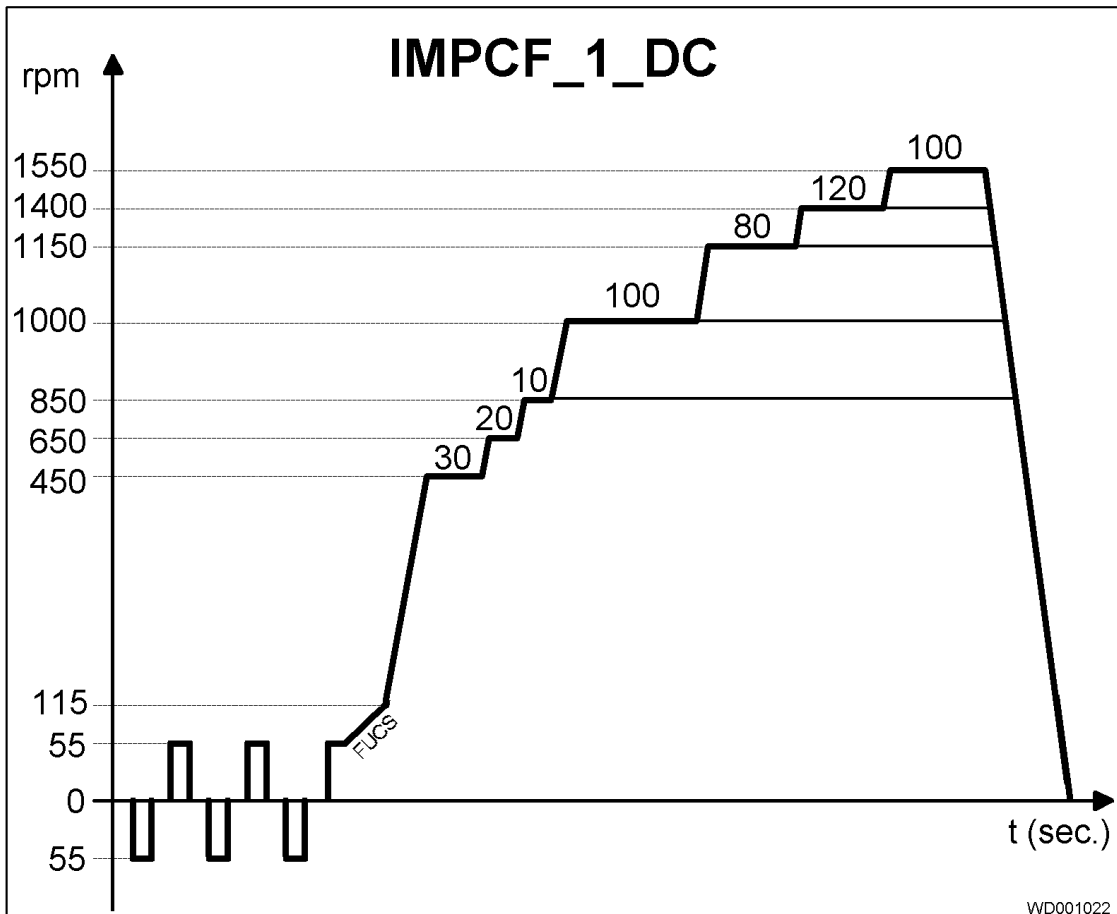

TECHNICAL CHARACTERISTICS

EWM 2000 ELECTRONIC CONTROL UNIT

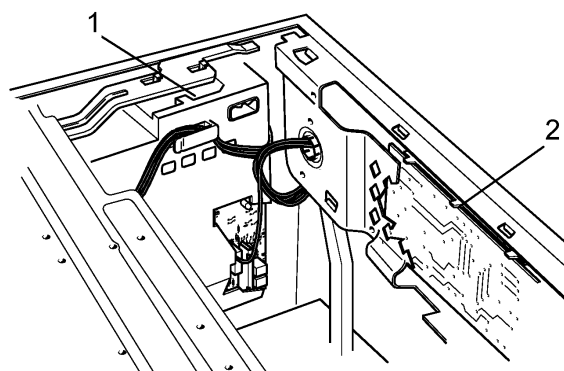

1. Main PCB
2. Control/Display Board

wd000601

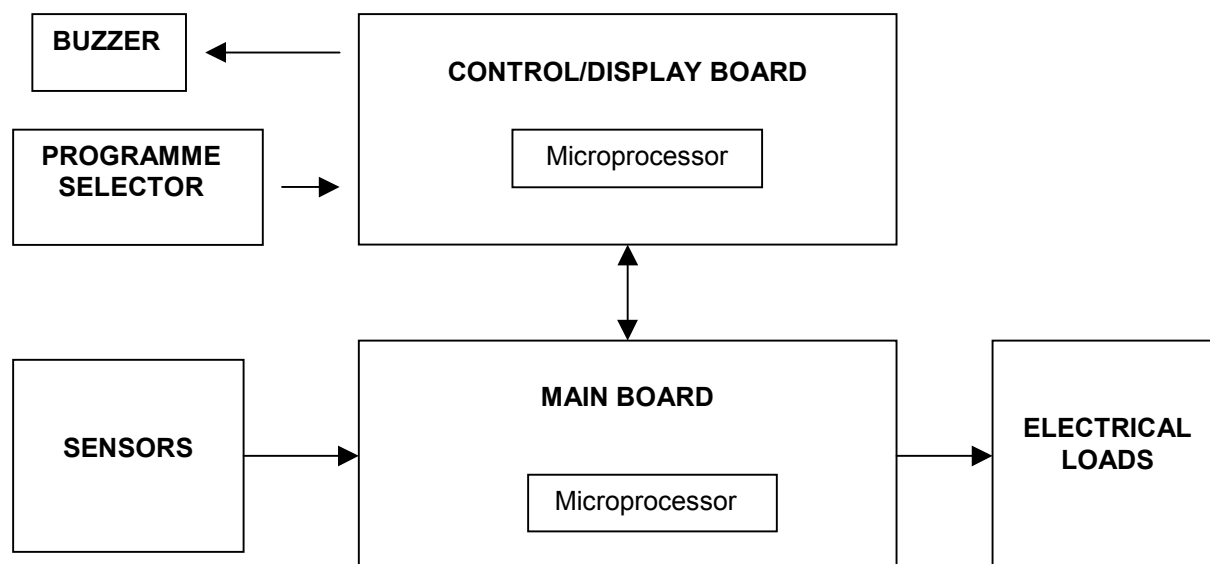

The main PCB performs the following functions:

- acquisition of the wash cycle settings via the control/display board.
- control of the water level in the tub via the electronic pressure switch and the safety pressure switch.
- control of the temperature of the washing solution via an NTC sensor.
- control of the speed of rotation of the motor via a signal from the tachometric generator.
- powering of all the electrical components in the washing machine and control of the wash cycle.

Several basic versions of the main PCB are available:

one for washing machines with AC motors

one for washer/dryers with AC motors

one for washing machines and washer/dryers with DC motors

MICROPROCESSOR MEMORY (MAIN PCB)

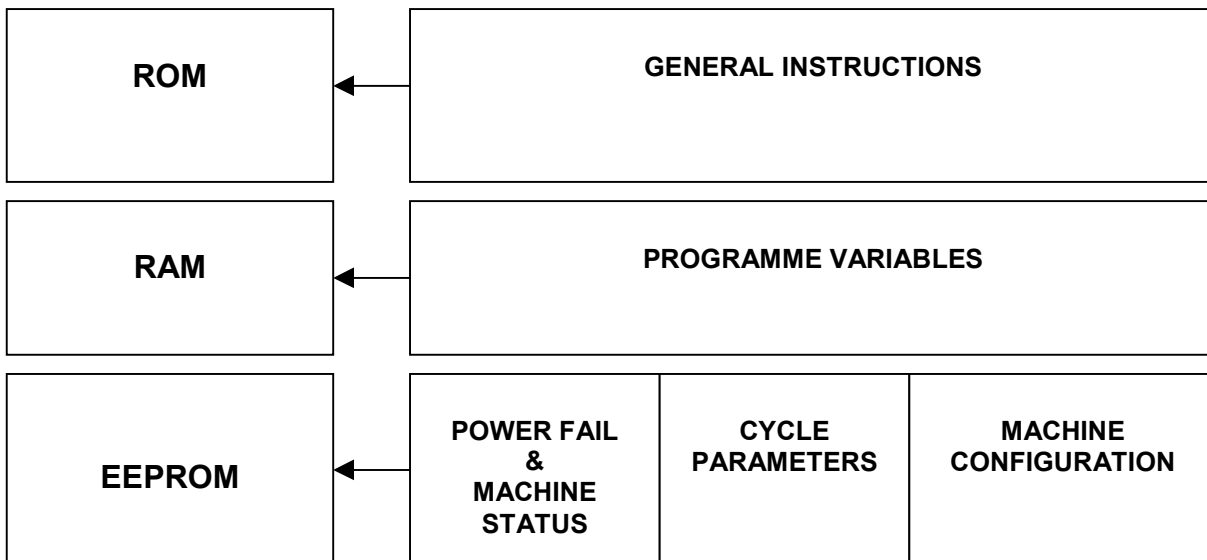

The overall structure of the microprocessor memory on the main PCB is subdivided into three sections:

ROM This area of memory contains the software with the general instructions that control the operation of the appliance, such as those of the electrical components and alarms. The ROM is set up by the manufacturer of the microprocessor, and cannot be modified.

RAM This part of memory contains all the variables used during the execution of the wash programme, which are written in dynamic format. The RAM can be read using a DAAS interface.

EEPROM This area of memory contains:

- the data necessary to restart the appliance in case of a power failure.
- the parameters for the wash cycle, such as water fill level, speed and type of motor movement, and the temperature during the various phases of the wash cycle. Once written, this data is protected and, normally, can be read only using a DAAS interface
- data relative to the configuration of the appliance, such as the speed of the final spin phase, the volume of the tub, the type of washing system, etc. This data may be entered either via a DAAS interface or via the control/display board.

ENTERING DATA INTO THE EEPROM

All the data is entered into the EEPROM on the production line using a computer with a DAAS interface.

In the field, the configuration only can be modified using a combination of buttons on the control/display board.

ELECTRONIC PRESSURE SWITCH

The electronic pressure switch is an analog device that controls the water level in the tub. It is directly connected to the main electronic PCB.

- 1. air inlet hose
- 2. diaphragm
- 3. coil
- 4. electronic circuit (oscillator)
- 5. core
- 6. spring
- 7. calibration screw
- 8. connector

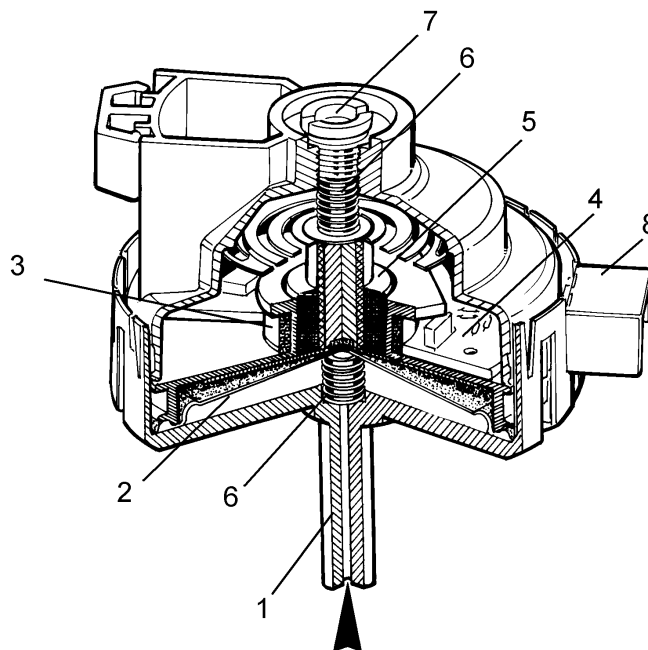

The pressure switch is connected by a hose to the pressure chamber.

When the tub is filled with water, the pressure created inside the hydraulic circuit expands the diaphragm. This in turn modifies the position of the core inside the coil, thus changing the inductance and the frequency of the oscillating circuit.

The electronic PCB, according to the frequency, recognizes the quantity of the water in the tub.

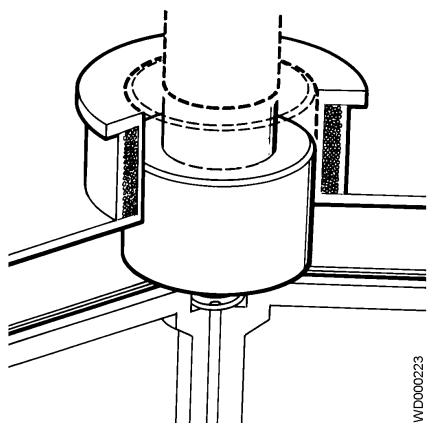

WID000223

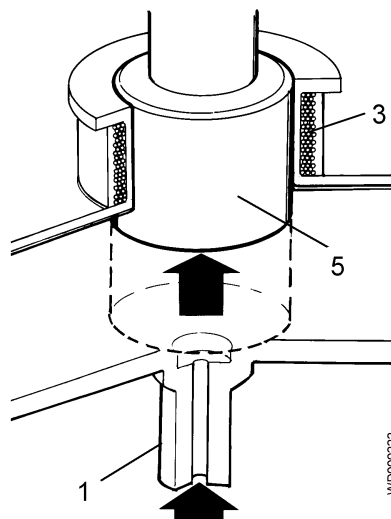

WID000222

Frequency variation according to pressure:

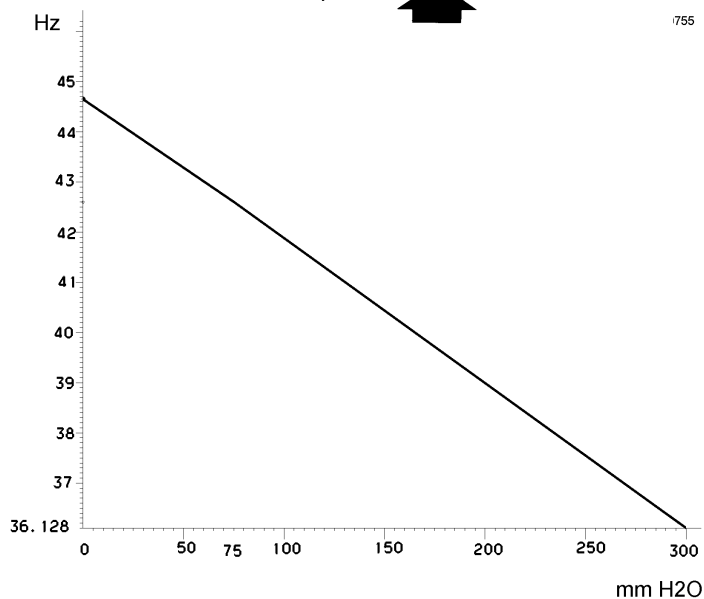

755

INSTANTANEOUS DOOR SAFETY DEVICE

Certain models are fitted with an instantaneous door safety device; this means that the door can be opened as soon as the drum stops rotating.

1. PTC solenoid protector
2. Solenoid
3. Lever mechanism
4. Cam
5. PTC - bimetal
6. Electrical contacts (main switch)
7. Latch

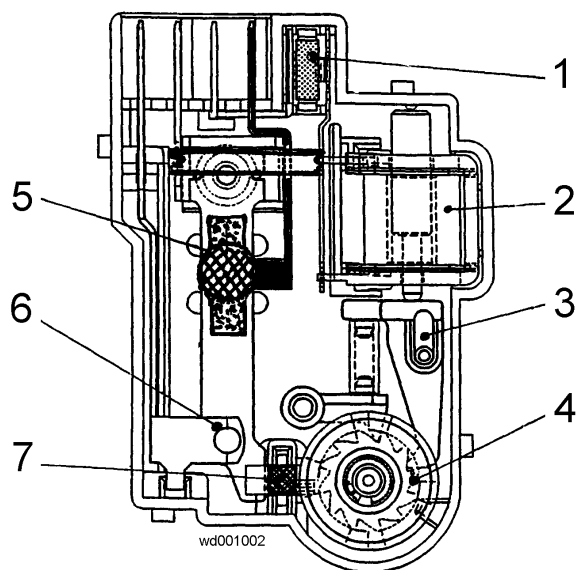
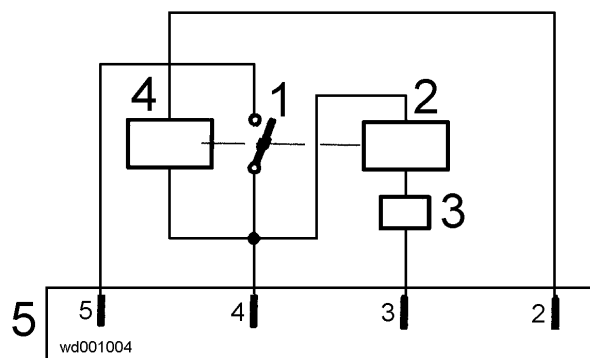

1. Main switch
2. Solenoid
3. PTC solenoid protection
4. Bimetal PTC
5. Connector

Operating principles

- When the ON/OFF button is pressed to switch the appliance on, the bimetal PTC is powered; the cam is in a position which prevents the latch from moving outwards.
- When the START/PAUSE button is pressed to start the programme, the main PCB transmits a signal (duration 20 msec) to the solenoid (at least 6 seconds after the appliance is switched on). The solenoid causes the cams to rotate one position. This raises the latch which holds the cursor of the door safety device in position and, at the same time, closes the contacts of the main switch, which thus powers all the components in the appliance.
- At the end of the programme, the board transmits two signals (at an interval of 200 msec and having the same 20 msec duration):
 - the first signal moves the cams a further position, though without releasing the latch.
 - the second signal (which is transmitted only if the system functions correctly) moves the cams another position, which causes the latch to retract, thus releasing the safety device. At the same time, the contacts of the main switch are opened.

Conditions for door aperture

Before transmitting the door aperture signal, the main PCB checks that the following conditions are observed:

- the drum must be stationary (i.e. no signal received from the tachometric generator)
- the water must not be above the lower lip of the door
- the temperature of the water must be not more than 40°C.

Automatic release device

In case of a power failure, or if the appliance is switched off using the ON/OFF button, or if the solenoid should malfunction, the bimetal PTC cools over a period varying from 55 seconds to 4 minutes (at a temperature of 65°C), after which the door lock is released.

Solenoid protection

A PTC is connected in series with the solenoid with the purpose of limiting the current (and thus possible overheating) in the following cases:

- TRIAC on the main PCB short-circuited
- Repeated actioning of the START/PAUSE button (more than 10 times)

DETERGENT DISPENSER

Water is ducted into the detergent dispenser by a solenoid valve with one inlet and two or three outlets. Some models are fitted with a second solenoid valve for hot water fill.

The same detergent dispenser is used in all models; the only difference lies in the water intake nozzle. The detergent dispenser may consist of three or four compartments.

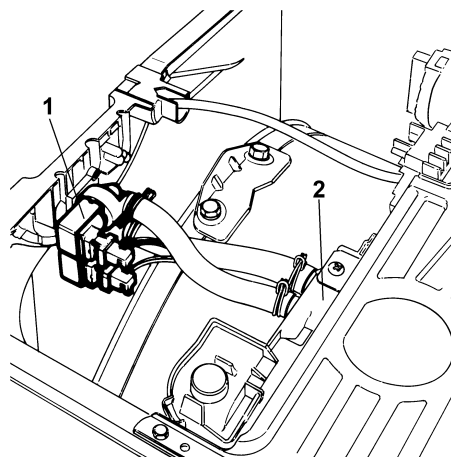

1. Solenoid valve
2. Detergent dispenser

The various combinations of detergent dispenser / nozzle for the various models are as follows:

3 compartments: pre-wash, wash, conditioners (1 two-way solenoid valve)

3 compartments + hot water: pre-wash, wash, conditioners (1 two-way solenoid valve + 1 solenoid valve for hot water fill)

4 compartments: pre-wash, wash, conditioners, bleach (1 three-way solenoid valve)

Water fill to pre-wash compartment (pre-wash solenoid)

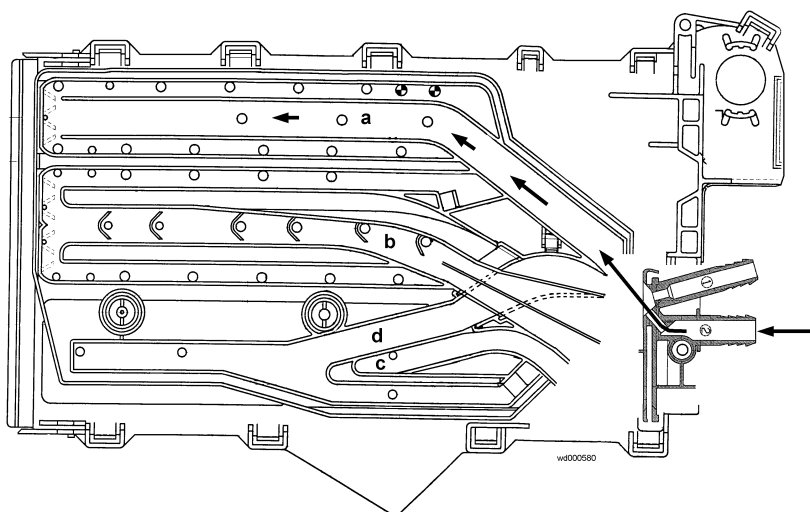

Water fill to wash compartment (wash solenoid)

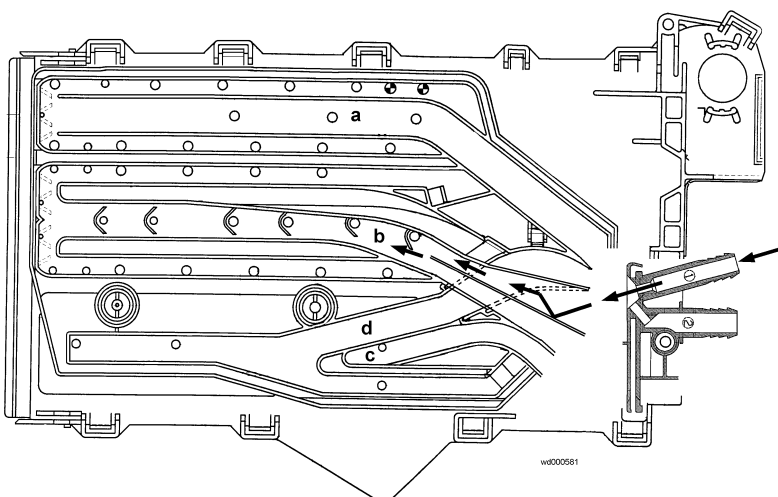

Water fill to conditioner compartment (pre-wash and wash solenoids)

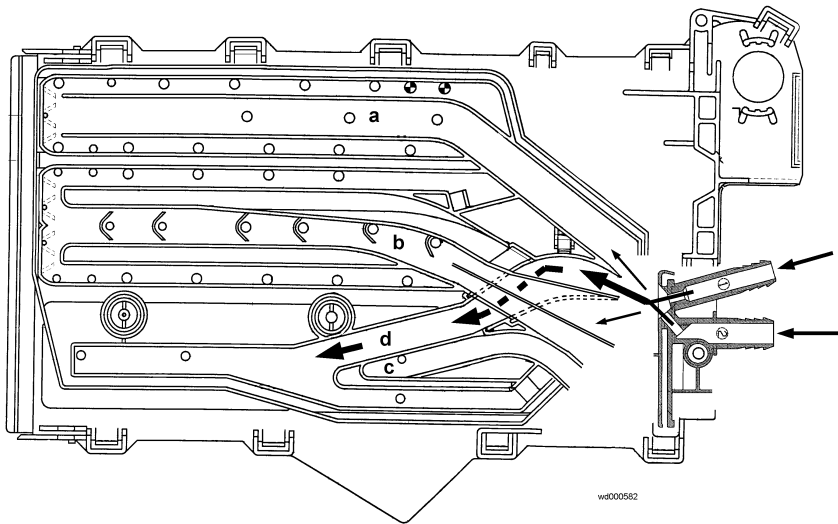

Water fill to bleach compartment (bleach solenoid)

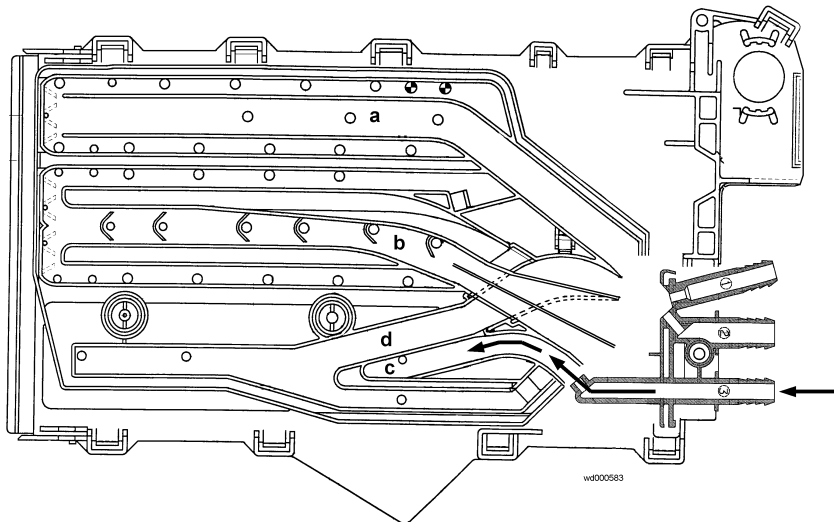

Hot water fill (hot water/wash solenoids)

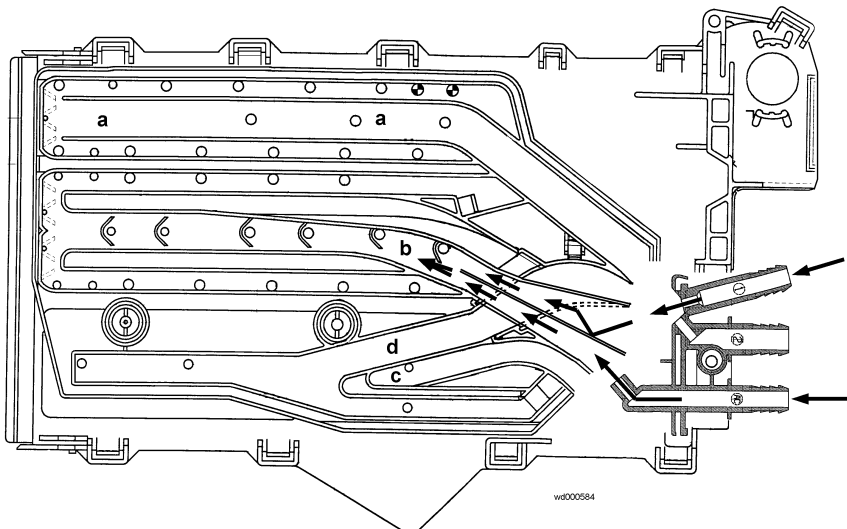

Power supply to the motor

The main PCB powers the motor directly via a TRIAC. Reversal of the direction of the motor is effected by two relays that vary the connection between the rotor and the stator. A third relay powers the stator in half- or full-range operation, depending on the spin speed.

The speed of the motor is controlled by a signal received from the tachometric generator.

During the spin cycles, the microprocessor checks for an unbalanced load and for excessive foam.

AC/DC converter

This component, which is fitted to certain models only, serves to convert the alternating current generated by the TRIAC on the main PCB into a direct current to power the drum motor.

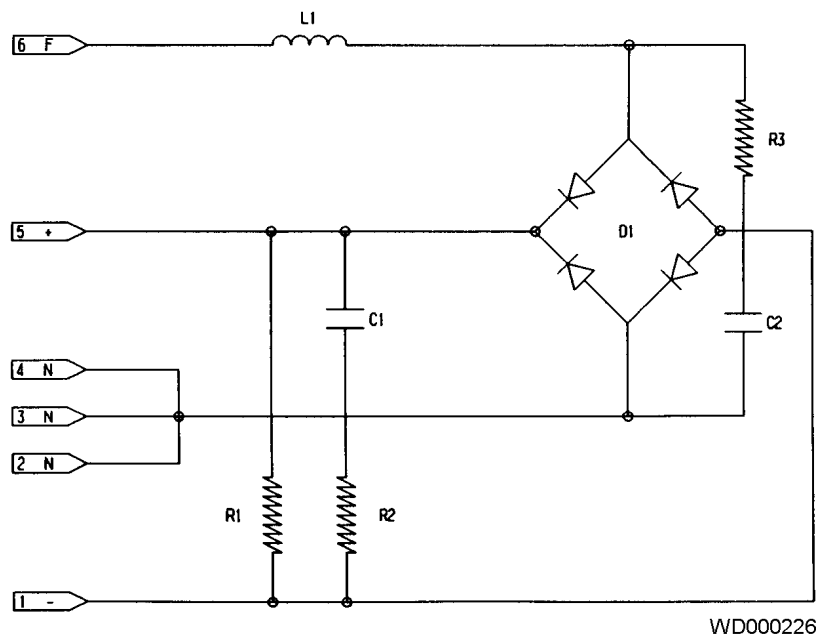
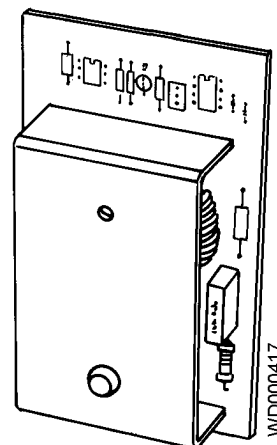

L1	1.2 mH	R1	68 KΩ
D1	25A/600V	R2-R3	100 Ω
C1-C2	47μF		

Circulation pump

In Jetsystem models, the circulation pump is powered directly by the main PCB via a TRIAC

Heating

The heating element is powered directly by the main PCB via a relay.

As a safety feature, a traditional dual-level pressure switch (anti-boiling 1 and anti-boiling 2) is connected in series to the heating element.

The temperature is controlled directly by the main PCB via an NTC temperature sensor. Two versions of the NTC sensor exist, depending on the type of tub; their shape is different, but their characteristics are identical.

1. Plastic casing
2. Metallic capsule
3. NTC resistor
4. Terminals

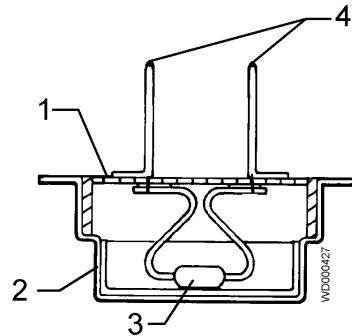

1. NTC resistor
2. Metallic capsule
3. Terminals
4. Plastic casing

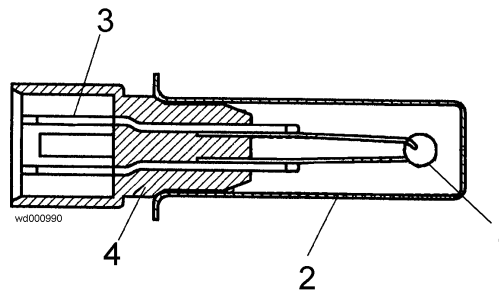

TEMPERATURE (°C)	RESISTANCE (Ω)		
	Rated	Maximum	Minimum
20	6050	6335	5765
60	1250	1278	1222
80	640	620	660

Drain cycle

The drain pump is powered directly by the main PCB via a TRIAC.

DRYING (washer/dryers only)

The drying system is identical to that used for washer/dryers with traditional timers.

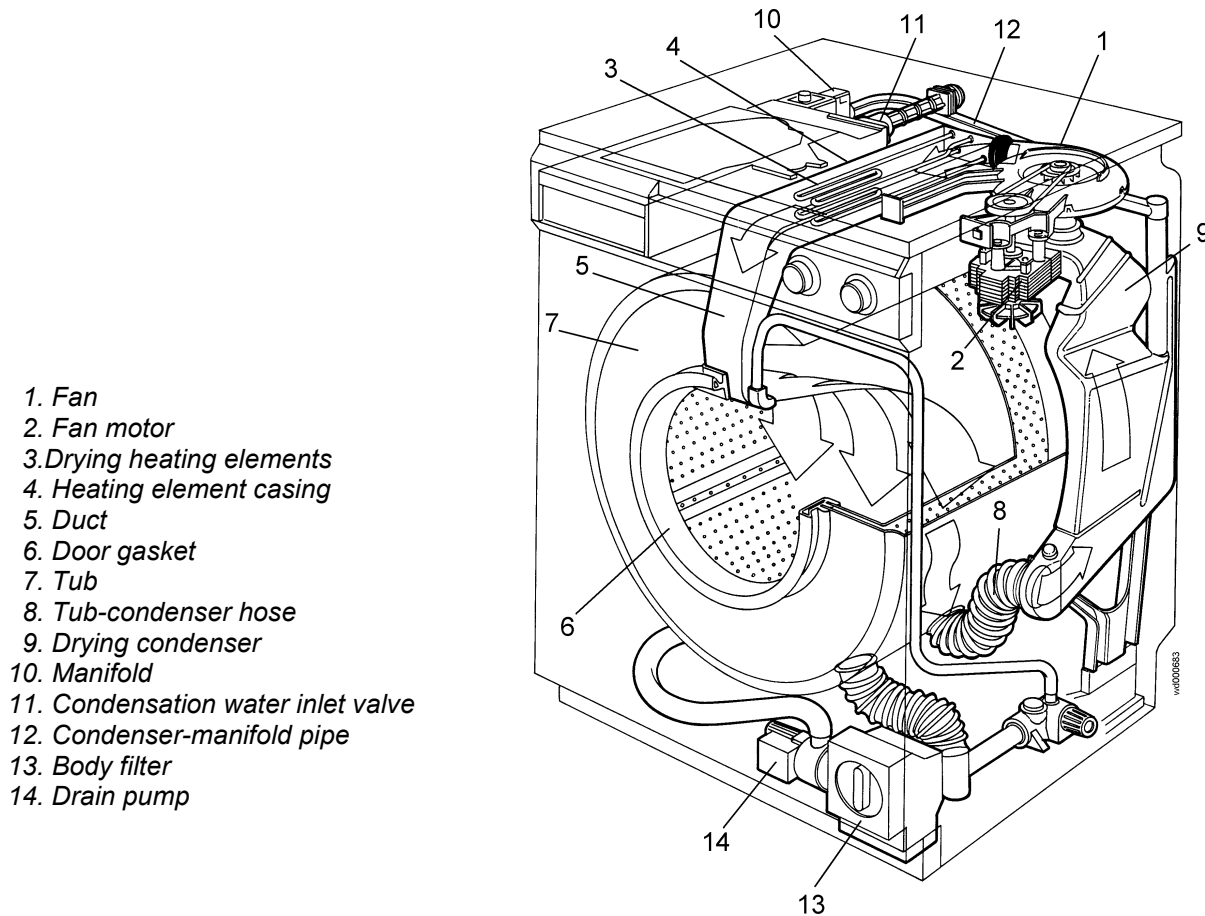

Automatic drying cycles: the drying time is controlled by the microprocessor to provide the desired level of humidity.

The drying cycle may be carried out at the end of the washing cycle or separately.

Three types of drying can be selected:

- Extra dry (only cotton)
- Store dry (cotton and synthetics)
- Iron dry (only cotton)

Time-controlled cycles: the drying time is selected by the user (maximum 130 minutes for cottons, 100 minutes for synthetics).

At the end of all drying cycles, a cooling phase takes place.

The drying heater is powered directly by the main PCB via two relays and the contacts of the safety pressure switch.

In cycles for synthetic fabrics, drying takes place with only one of the branches of the heating element in operation (half-power). For cotton cycles, both branches of the heating element are used (full power).

The fan motor is powered by a different relay; the solenoid valve is powered by a TRIAC.

Temperature control:

An NTC sensor fitted to the duct is used to control the drying temperature; two safety thermostats (one of which is a manual-reset type) are fitted to the casing of the heating element.

1. NTC sensor for control of drying temperature
2. Safety thermostat (98°C)
3. Manual-reset safety thermostat (150°C)
4. Drying heater

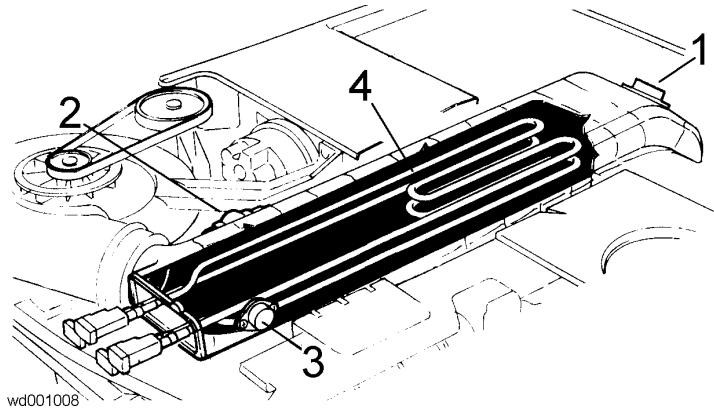

Determining the drying time:

In automatic cycles, the NTC sensor fitted to the drying condenser is used to control the drying time.

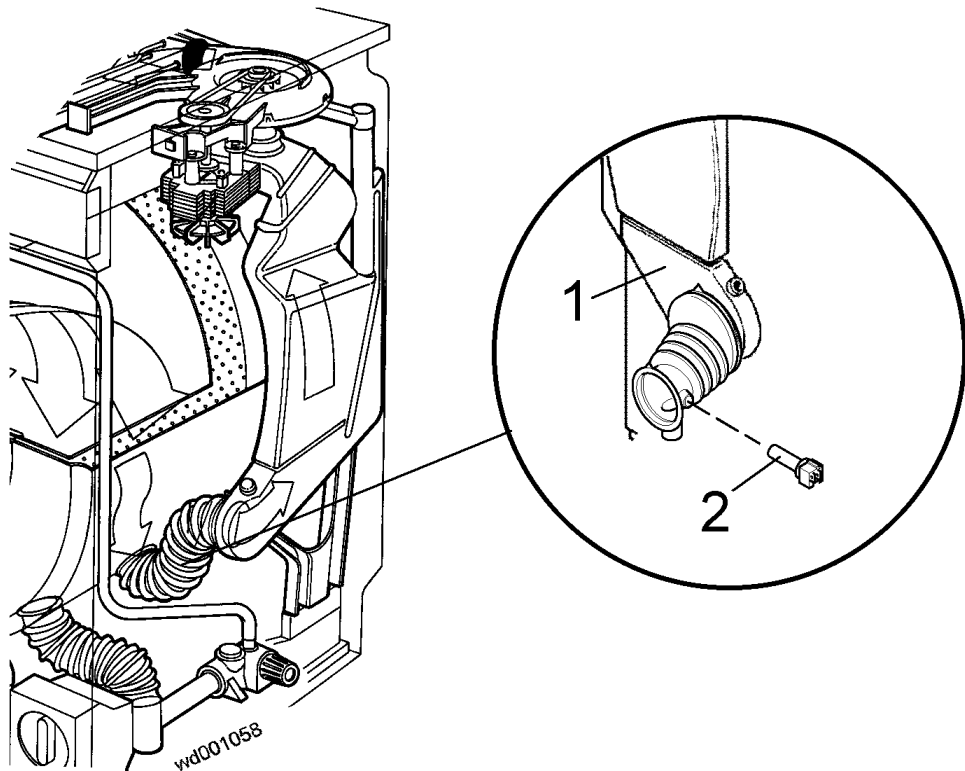

1. Drying condenser
2. NTC temperature sensor (drying time)

ACCESS TO THE DIAGNOSTICS / CONFIGURATION SYSTEM

Using a single procedure, it is possible to access both the diagnostics and configuration systems. After accessing this function, the following operations can be performed:

- configuration of the main PCB
- analysis of alarm conditions
- control of the operation of each of the components in the appliance.

To access the system:

switch off the appliance and turn the programme selector knob to RESET.

press the START/PAUSE button together with one of the other buttons and then, holding down both buttons, press the ON/OFF button to switch on the appliance.

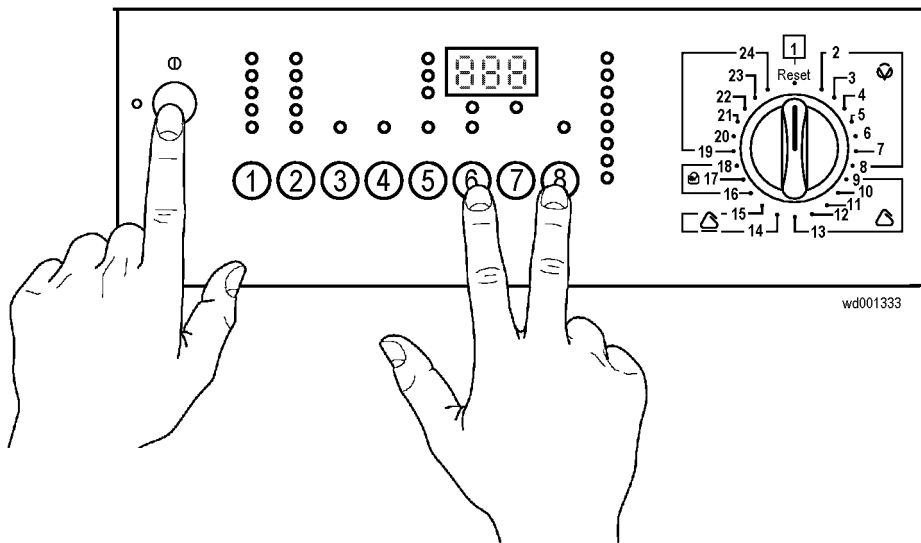

hold both buttons down until the buzzer (if featured) sounds and the LEDs begin to flash (about 4 seconds)

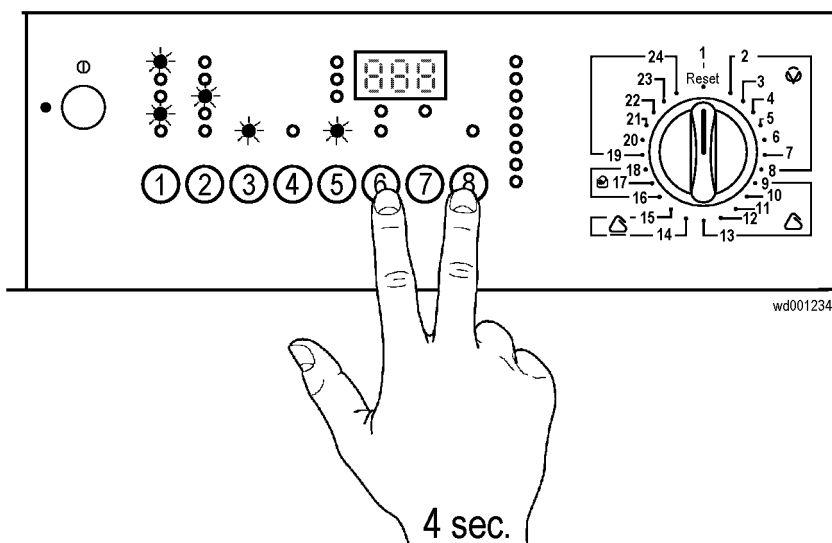

DIAGNOSTICS SYSTEM

The diagnostics system is used to check the operation of all the components of the washing machine. After accessing the diagnostics routine (see "Access to the diagnostics / configuration system"), the correct operation of each component can be checked by turning the programme selector knob clockwise.

CHECKING THE DISPLAY BOARD

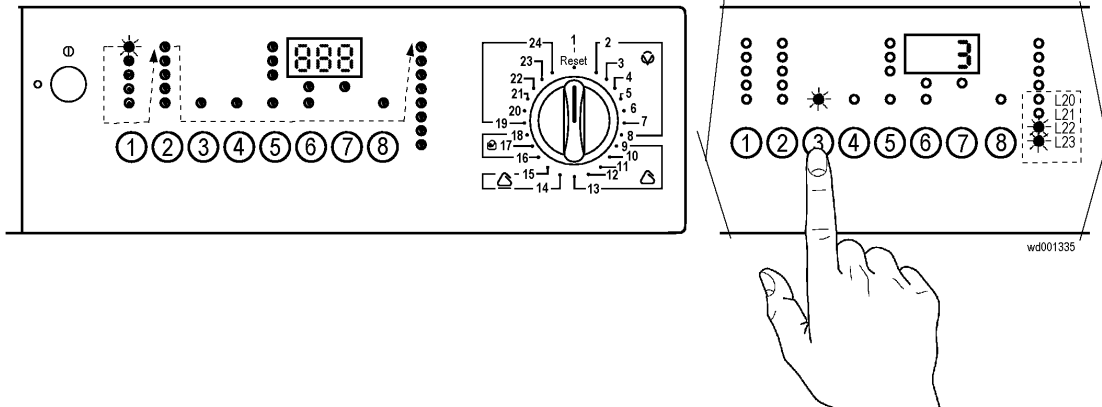

When the knob is in the first position (RESET) (after accessing the diagnostics system), the system checks the display board.

The programme selector code is displayed for the first two seconds on the wash phase indicator LEDs, after which all the LEDs light in sequence (as well as the display, if featured).

When each button is pressed, the corresponding LED lights; the wash phase LEDs (and the display) show the binary code corresponding to the code relative to the button pressed.

Table of button codes

BUTTON No.		0	1	2	3	4	5	6	7	8
LED	L20	<input type="checkbox"/>	<input type="checkbox"/>	<input type="checkbox"/>	<input type="checkbox"/>	<input type="checkbox"/>	<input type="checkbox"/>	<input type="checkbox"/>	<input type="checkbox"/>	<input type="checkbox"/>
	L21	<input type="checkbox"/>	<input type="checkbox"/>	<input type="checkbox"/>	<input type="checkbox"/>	<input type="checkbox"/>	<input type="checkbox"/>	<input type="checkbox"/>	<input type="checkbox"/>	<input type="checkbox"/>
	L22	<input type="checkbox"/>	<input type="checkbox"/>	<input type="checkbox"/>	<input type="checkbox"/>	<input type="checkbox"/>	<input type="checkbox"/>	<input type="checkbox"/>	<input type="checkbox"/>	<input type="checkbox"/>
	L23	<input type="checkbox"/>	<input type="checkbox"/>	<input type="checkbox"/>	<input type="checkbox"/>	<input type="checkbox"/>	<input type="checkbox"/>	<input type="checkbox"/>	<input type="checkbox"/>	<input type="checkbox"/>

- LED off
- LED lit

The display board test is performed automatically even if the board is powered while not connected to the main PCB and the programme selector.

DIAGNOSTICS CYCLE

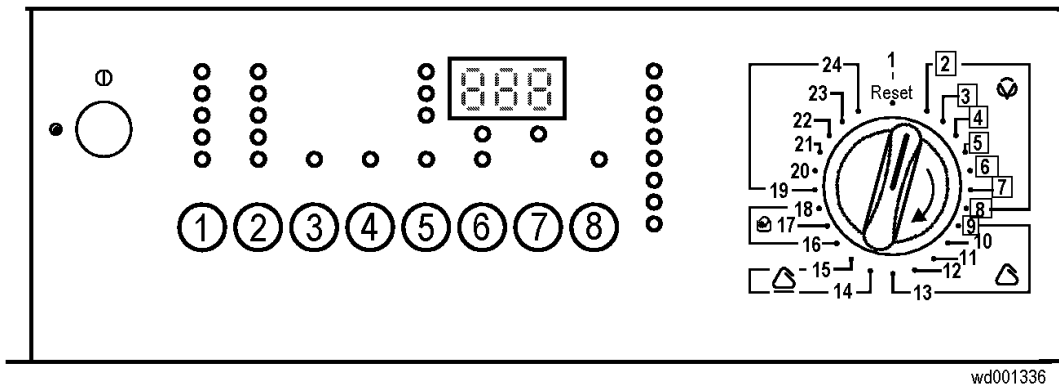

Correct operation of all the components in the appliance can be checked by turning the programme selector knob clockwise.

The diagnostics cycles can be performed only if there is correct communication (connection) between the main PCB and the display board; also, the configuration of the appliance must be correct.

The wash phase LEDs (and the display, if featured) show the binary code representing the closure of the programme selector contacts for two seconds.

After two seconds, all the LEDs switch off and the diagnostics cycle corresponding to the position of the knob is performed.

If an alarm condition occurs during the diagnostics cycle, operation of the appliance is interrupted, and the LEDs (and display) show the corresponding alarm code (flashing).

To exit the diagnostics cycle, switch the appliance off, on, and then off again.

DIAGNOSTICS CYCLE PHASES

Knob position	Function tested	Components actioned	Operating conditions	Parameters displayed
1	Operation of the display board	All the LEDs light in sequence. When a button is pressed, the corresponding LED lights	Always operative	Button code
2	Water fill to wash compartment	- door interlock - wash solenoid	Door closed, water fill to anti-overflow level for max. 10 min	Water level in mm
3	Water fill to pre-wash compartment	- door interlock - pre-wash solenoid	Door closed, water fill to anti-overflow level for max. 10 min	Water level in mm
4	Water fill to conditioner compartment	- door interlock - pre-wash solenoid - wash solenoid	Door closed, water fill to anti-overflow level for max. 10 min	Water level in mm
5	Hot water fill or fill to bleach compartment (certain models only)	- door interlock - hot water or bleach solenoid	Door closed, water fill to anti-overflow level for max. 10 min	Water level in mm
6	Heating (and, in Jetsystem models, recirculation)	- door interlock - (wash solenoid if level is lower than the antiboiling device) - recirculation pump (Jetsystem models) - heating element	Door closed, water fill to above anti-boiling level if not yet reached, heating for max. 10 min or to 90°C	Water temperature in °C
7	Check for leaks from tub	- door interlock - (wash solenoid if level is <150mm) - motor	Door closed, water fill above 150mm level if not yet reached, motor until the drum reaches 250 rpm	Motor speed (rpm)
8	Drain and spin, check for pressure switch congruency	- door interlock - drain pump - motor	Door closed, water drain, motor movement, until maximum spin speed is reached	Motor speed (rpm ÷ 10)
9	Drying (washer/dryers only)	- door interlock - drain pump - drying heater (full power) - fan motor - condensation solenoid	Door closed, water drain to a level lower than the anti-boiling device, drying heater for max. 10 min or until the drying temperature sensor (fitted to the duct) detects a temperature of 150°C	NTC drying temperature and condenser temperature (°C, displayed alternately for 2 sec)

If an alarm condition occurs during the course of the diagnostics cycle, the appliance stops and the display or LEDs flash to indicate the alarm code.

PROGRAMME SELECTOR

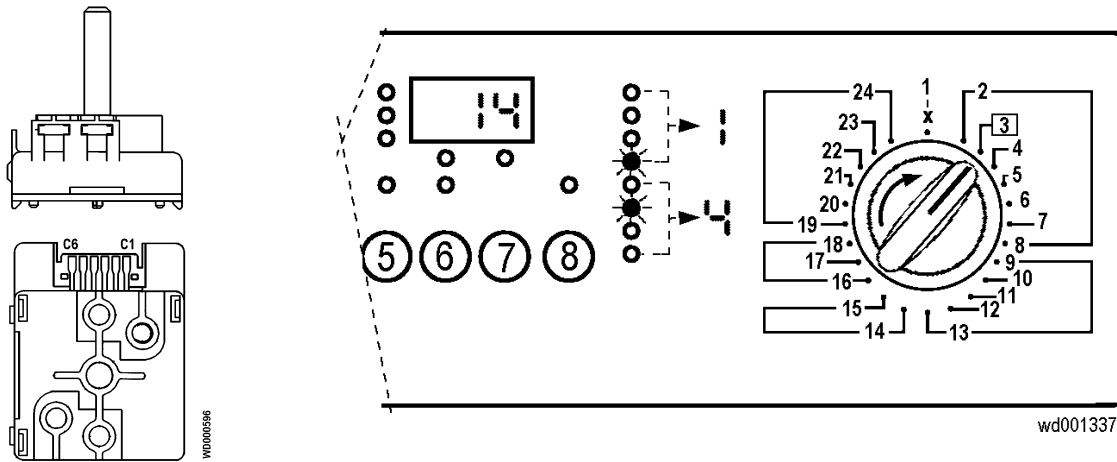

The table below shows the closure sequence of contact C6 (common) and the other contacts (C1 - C5) of the programme selector in the various positions, as well as the light-up sequence of the display.

24-position selector knob	12-position selector knob (C1 not present)	Closure of selector contacts (C6 = common)					Display code
		C1	C2	C3	C4	C5	
1 - Reset	1 - Reset	0	1	1	1	1	1 E
2	2	0	1	0	0	1	0 6
3	-	0	1	1	0	0	1 4
4	3	0	1	0	1	0	0 C
5	-	0	1	1	1	0	1 C
6	4	0	0	0	1	1	0 A
7	-	1	0	0	0	0	0 1
8	-	1	0	0	0	1	0 3
9	-	1	0	0	1	0	0 9
10	5	0	1	0	1	1	0 E
11	-	0	0	1	0	1	1 2
12	-	1	0	0	1	1	0 b
13	-	1	0	1	0	0	1 1
14	-	0	0	1	1	0	1 8
15	6	1	0	1	0	1	1 3
16	-	0	0	1	1	1	1 A
17	7	1	0	1	1	0	1 9
18	8	1	0	1	1	1	1 b
19	-	1	1	0	0	0	0 5
20	9	0	1	1	0	1	1 6
21	-	0	0	0	0	1	0 2
22	10	0	1	0	0	0	0 4
23	11	0	0	0	1	0	0 8
24	12	0	0	1	0	0	1 0

ALARMS

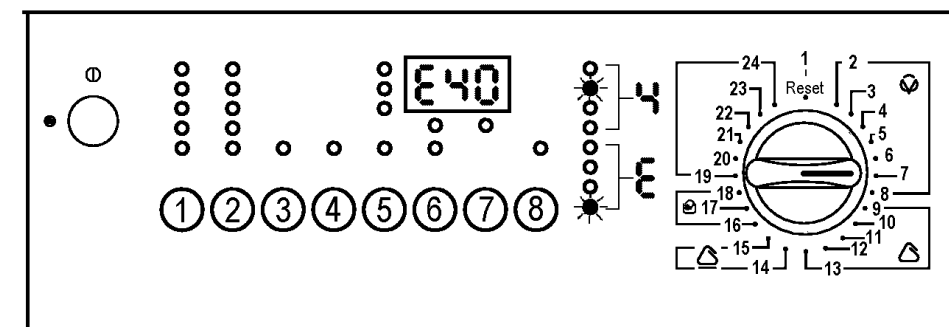

wd001338

The electronic control unit detects and recognises any malfunctions in the operation of the appliance, in which case an alarm condition is generated. Alarm conditions may be of three types:

- cycle paused
- cycle blocked
- current phase skipped

Only four alarm conditions are normally displayed to the user:

problems with water fill
 problems with drain
 door open
 communication error between the electronic boards, or configuration error.

In the first three cases, the cycle is paused so that the user can, if possible, solve the problem. The code showing the type of alarm flashes on the display.

In models without a display window, the last wash phase LED (end) flashes; the code relative to the type of alarm flashes on the first four LEDs (and on the display).

For example, in the case of alarm **E41** (door open), the display will show **E40**. In models not featuring a display window, as well as the end-of-cycle LED which indicates error "E", the second LED indicates 4 in binary code.

As can be seen from the general alarm code table, **E4..** alarm conditions include all alarms relative to door closure problems:

- **E41:** door open
- **E42:** door interlock malfunction
- **E43, E44, E45:** problems with main PCB or wiring

In the case of communication or configuration errors, the alarm is displayed immediately when the appliance is switched on; in the event of configuration errors, the only possible action is to access the diagnostics system.

The FILTER BLOCKED alarm is signalled by the corresponding LED (if featured) only at the end of the cycle; **EF0** flashes on the display.

To exit the alarm condition, press START/PAUSE if the cycle is paused (this enables the appliance to attempt to complete the operation under the control of the user) or, if the cycle has been interrupted, switch off the appliance.

READING THE LAST ALARM CONDITION

The diagnostics system makes it possible to identify the last alarm condition which occurred during the operation of the appliance.

to read this alarm condition, after accessing the diagnostics system (see "Access to the diagnostics / configuration system), **turn the programme selector knob two positions counter-clockwise** from the RESET position.

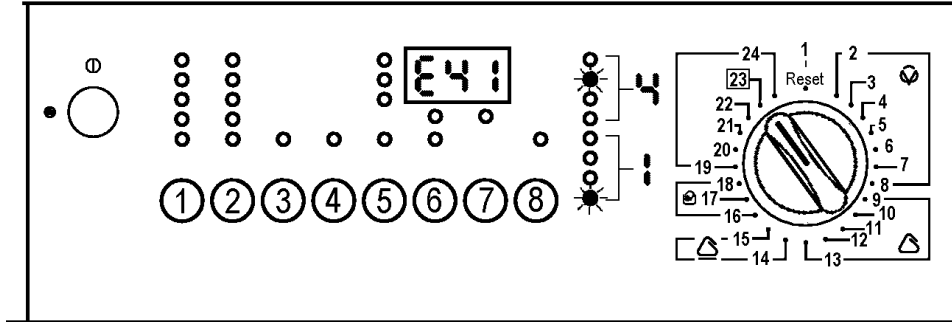

wd001339

The alarm condition is displayed; the corresponding binary code flashes on the wash phase LEDs (and on the display).

the first four LEDs indicate the first digit of the alarm code

the second four LEDs indicate the second digit of the alarm code

For example, if an **E41** alarm condition (door open) is generated, the display will show **E41** and, at the same time, the second LED in group **A** (equivalent to **4** in binary code) and the fourth LED (equivalent to **1** in binary code) will also flash.

*If no alarm conditions have occurred, the display shows **E00**.*

DIAGNOSTICS CYCLE ALARMS

If a malfunction should occur during the course of the diagnostics cycle, the relative alarm codes are displayed. In this case, too, the wash phase LEDs (and the display) show the error code (flashing).

BINARY CODES

The table below shows how to convert the binary code displayed by the LEDs into the corresponding decimal number.

0	1	2	3	4	5	6	7	8	9	10	11	12	13	14	15
										A	b	C	d	E	F
<input type="checkbox"/>	<input type="checkbox"/>	<input type="checkbox"/>	<input type="checkbox"/>	<input type="checkbox"/>	<input type="checkbox"/>	<input type="checkbox"/>	<input type="checkbox"/>	<input type="checkbox"/>	<input type="checkbox"/>	<input type="checkbox"/>	<input type="checkbox"/>	<input type="checkbox"/>	<input type="checkbox"/>	<input type="checkbox"/>	<input type="checkbox"/>
<input type="checkbox"/>	<input type="checkbox"/>	<input type="checkbox"/>	<input type="checkbox"/>	<input type="checkbox"/>	<input type="checkbox"/>	<input type="checkbox"/>	<input type="checkbox"/>	<input type="checkbox"/>	<input type="checkbox"/>	<input type="checkbox"/>	<input type="checkbox"/>	<input type="checkbox"/>	<input type="checkbox"/>	<input type="checkbox"/>	<input type="checkbox"/>
<input type="checkbox"/>	<input type="checkbox"/>	<input type="checkbox"/>	<input type="checkbox"/>	<input type="checkbox"/>	<input type="checkbox"/>	<input type="checkbox"/>	<input type="checkbox"/>	<input type="checkbox"/>	<input type="checkbox"/>	<input type="checkbox"/>	<input type="checkbox"/>	<input type="checkbox"/>	<input type="checkbox"/>	<input type="checkbox"/>	<input type="checkbox"/>
<input type="checkbox"/>	<input type="checkbox"/>	<input type="checkbox"/>	<input type="checkbox"/>	<input type="checkbox"/>	<input type="checkbox"/>	<input type="checkbox"/>	<input type="checkbox"/>	<input type="checkbox"/>	<input type="checkbox"/>	<input type="checkbox"/>	<input type="checkbox"/>	<input type="checkbox"/>	<input type="checkbox"/>	<input type="checkbox"/>	<input type="checkbox"/>

- LED OFF
- LED LIT

ALARM CODES

0: LED off 1: LED flashing

Alarm code	LED L16÷19	LED L20÷23	Description of fault	User code	Effect	Possible causes
E11	0 0 0	0 0 0	Problems with water fill in wash phase (maximum 10 minutes for each fill phase)	E10	Cycle PAUSED	Tap closed or mains pressure insufficient; solenoid valve; hydraulic circuit of pressure switches; pressure switches; wiring; main PCB
E12	0 0 0	0 0 1	Problems with water fill in drying phase (maximum 10 minutes for each fill phase during in the wash load untangling phase)	E10	Cycle PAUSED	Tap closed or mains pressure insufficient; solenoid valve; hydraulic circuit of pressure switches; pressure switches; wiring; main PCB
E21	0 0 1	0 0 0	Problems with water drain in wash phase (maximum 10 minutes for each drain phase)	E20	Cycle PAUSED	Drain hose obstructed; filter blocked; drain pump; pressure switches; wiring; main PCB
E22	0 0 1 0	0 0 1 0	Problems with water drain during drying or drying condenser blocked (anti-boiling pressure switch closed on "full")	E20	Heating phase skipped	Drain hose obstructed; filter blocked; drying condenser blocked; drain pump; pressure switches; wiring; main PCB
E31	0 0 1	0 0 0	Electronic pressure switch circuit faulty (frequency of pressure switch signal out of limits)	---	Cycle blocked with door closed	Electronic pressure switch; wiring; main PCB
E32	0 0 1 1	0 0 1 1	Incorrect calibration of electronic pressure switch (electronic pressure switch level different from 0-66 mm after initial calibration drain and anti-boiling pressure switch on "empty")	---	Cycle PAUSED	Tap closed or mains pressure insufficient; solenoid valve; hydraulic circuit of pressure switches; pressure switches; wiring; main PCB
E33	0 0 1 1	0 0 1 1	Incongruency between level of electronic pressure switch and level of anti-boiling pressure switch 1 (duration of fault at least 60 seconds)	---	Cycle blocked with door closed	Hydraulic circuit of pressure switches; electronic pressure switch; pressure switch; Loss of insulation on heaters; wiring; main PCB
E34	0 0 1 1	0 1 0 0	Incongruency between level of electronic pressure switch and level of anti-boiling pressure switch 2 (duration of fault at least 60 seconds)	---	Cycle blocked with door closed	Hydraulic circuit of pressure switches; electronic pressure switch; pressure switch; wiring; main PCB
E35	0 0 1 1	0 1 0 0	Water level too high (level of electronic pressure switch higher than 300mm for more than 15 seconds)	---	Cycle blocked with door closed and water drain to 120mm	Solenoid valve; hydraulic circuit of pressure switches; pressure switches; wiring; main PCB
E36	0 0 1 1	0 1 1 0	"Sensing" circuit of anti-boiling pressure switch 1 faulty (input signal to microprocessor always 0V or 5V)	---	Cycle blocked with door closed	Main PCB

E37	0 0 1 1	0 1 1 1	"Sensing" circuit of anti-boiling pressure switch 2 faulty (input signal to microprocessor always 0 - 5V)	---	Cycle blocked with door closed	Main PCB
E38	0 0 1 1	1 0 0 0	Pressure chamber blocked (water level does not vary for at least 30 sec. during drum rotation)	---	Heating phase skipped	Pressure switch hydraulic circuit; pressure switches, motor drive belt broken
E41	0 1 0 0	0 0 0 1	Door open (door delay interlock does not close after 15 seconds)	E40	Cycle paused	Door open; door delay interlock; wiring; main PCB
E42	0 1 0 0	0 0 1 0	Problems with door closure (door open during cycle for more than 15 sec. or door closed after cycle for more than 3 min.)	E40	Cycle paused	Door delay interlock; wiring; main PCB
E43	0 1 0 0	0 0 1 1	TRIAC which powers the door interlock faulty (incongruency between status of door interlock "sensing" circuit and status of TRIAC)	E40	Cycle paused	Wiring; main PCB
E44	0 1 0 0	0 1 0 0	"Sensing" circuit of door delay interlock faulty (input signal to microprocessor always 0V or 5V)	---	Cycle blocked	Main PCB
E45	0 1 0 0	0 1 0 1	"Sensing" circuit of door delay interlock triac faulty (input signal to microprocessor always 0V or 5V)	---	Cycle blocked with door closed	Main PCB
E51	0 1 0 1	0 0 0 1	TRIAC which powers the motor short-circuited (TRIAC short-circuit cut-out activated or motor speed more than maximum speed)	---	Cycle blocked with door closed (after 5 attempts)	Loss of insulation on motor winding/wiring; main PCB
E52	0 1 0 1	0 0 1 0	No signal from tachometric generator on motor (no signal after maximum time)	---	Cycle blocked with door closed (after 5 attempts, the last after 20 sec)	Motor; tachometric generator; wiring; main PCB
E53	0 1 0 1	0 0 1 1	"Sensing" circuit of motor TRIAC faulty (input signal to microprocessor always 0V or 5V)	---	Cycle blocked with door closed	Main PCB
E54	0 1 0 1	0 1 0 0	Relays contacts sticking (voltage on "sensing" circuit when the relays should be open)	---	Cycle blocked with door closed (after 5 attempts)	Loss of insulation on motor windings/wiring; main PCB

E55	0 1 0 1	0 1 0 1	Motor circuit open	---	Cycle blocked with door closed (after 5 attempts)	Motor; wiring; main PCB
E61	0 1 1 0	0 0 0 1	Insufficient heating during washing (maximum heating time exceeded)	---	Heating phase skipped	NTC sensor incorrectly calibrated; heating element; wiring; main PCB
E62	0 1 1 0	0 0 1 1	Overheating during washing (temperature >88°C for more than 5 minutes)	---	Drain, cycle blocked	Heating element (earthed); NTC sensor faulty; wiring; main PCB
E64	0 1 1 0	0 1 0 0	Overheating during drying (drying temperature >180°C detected by NTC temperature sensor on duct)	---	Heating phase for drying skipped	Drying NTC sensor (duct); drying heater; wiring; main PCB
E66	0 1 1 0	0 1 1 0	Power relay to heating element faulty (incongruency between closure of anti-boiling pressure switch 2 and status of relay K3)	---	Drain, cycle blocked	Anti-boiling pressure switch 2; wiring; main PCB
E71	0 1 1 1	0 0 0 1	NTC wash sensor faulty (voltage not within limits = short-circuit or open)	---	Heating phase skipped	Wash NTC sensor; wiring; main PCB
E72	0 1 1 1	0 0 1 1	NTC sensor on drying condenser faulty (voltage out of limits = short-circuit or open)	---	Heating phase for drying skipped	Drying NTC sensor (condenser); wiring; main PCB
E73	0 1 1 1	0 0 1 1	NTC sensor on drying duct faulty (voltage out of limits = short-circuit or open)	---	Heating phase for drying skipped	Drying NTC sensor (duct); wiring; main PCB
E84	1 0 0 0	0 1 1 0	"Sensing" circuit on circulation pump triac faulty (input signal to microprocessor always 0V or 5V)	---	Drain, cycle blocked (door open)	Main PCB
E85	1 0 0 0	0 1 0 1	Circulation pump faulty (incongruency between status of "sensing" circuit on circulation pump and status of TR/A/C)	---	Drain, cycle blocked (door open)	Circulation pump; wiring; main PCB
E91	1 0 0 1	0 0 0 1	Communications error between main PCB and display board	E90	---	Wiring; main PCB; display board

E92	1 0 0	0 0 1	0 0 1	Communications and display board (versions not compatible)	E90	---	Main PCB; display board
E93	1 0 0	0 0 1	0 0 1	Configuration error (incongruency of configuration values when appliance is switched on)	E90	Cycle blocked	Configuration error; main PCB
E94	1 0 0	0 1 0	0 1 0	Incorrect configuration of washing cycle	E90	Cycle blocked	Cycle software error; main PCB
EF1	1 1 1	0 0 0	0 0 1	Drain filter blocked (drain phase too long)	Specific LED (EF0)	---	Drain hose obstructed/kinked; drain filter dirty/blocked
EF2	1 1 1	0 0 1	0 0 0	Excessive detergent (too much foam during drains)	Specific LED (EF0)	---	Excessive detergent introduced; drain hose obstructed/kinked; drain filter dirty
EF3	1 1 1	0 0 1	0 0 1	Water leakage: intervention of Aqua Control system	---	Water drain to 120mm, cycle blocked	Leaks from base; drain pump; wiring; main PCB

0: LED off

1: LED flashing

CANCELLING THE LAST ALARM CONDITION

To cancel the last memorised alarm condition, press START/PAUSE button and no. 4 button at the same time during the course of the diagnostics cycle.

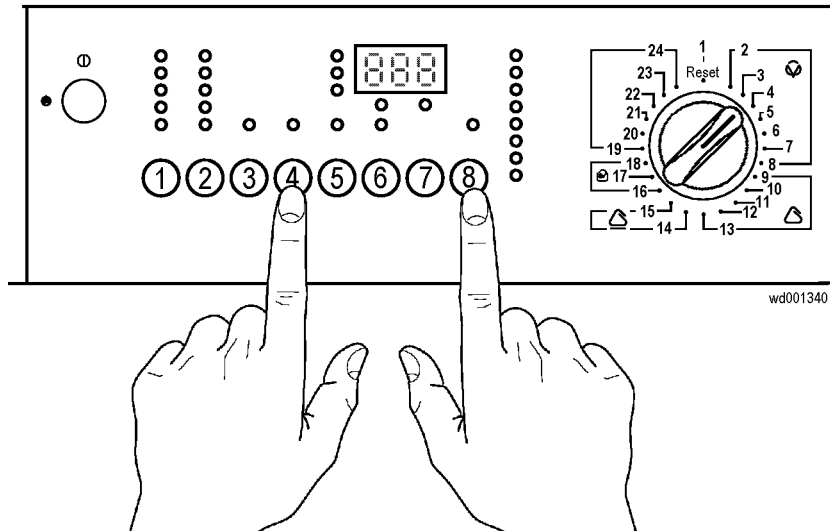

The alarm is cancelled also when a new configuration is given to the main PCB.

CONFIGURATION OF THE MAIN PCB

A standard main PCB is available as a spare part. This PCB contains only data relative to the wash cycle.

After replacing the main PCB, it is necessary to perform the configuration procedure in order to operate the washing machine.

Configuration of the board consists of entering a 16-digit code which contains information which varies from model to model (type of washing system, type of tub, type of appliance, spin speed, etc.).

To access the machine configuration procedure, first enter the diagnostics system, and then:

turn the programme selector one position counter-clockwise; the display window shows the code relative to the position of the programme selector and, after two seconds, the code relative to the first of the 16 digits of the configuration code (i.e. position 0).

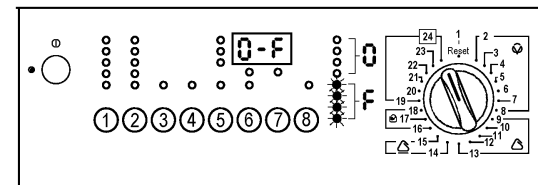

when one of the option buttons is pressed (with the exception of the START/PAUSE button), all the digits which make up the configuration code are displayed in sequence.

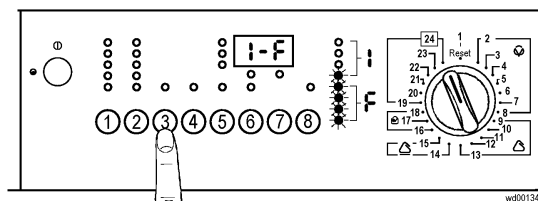

press the START/PAUSE button to modify the configuration code (digit by digit).

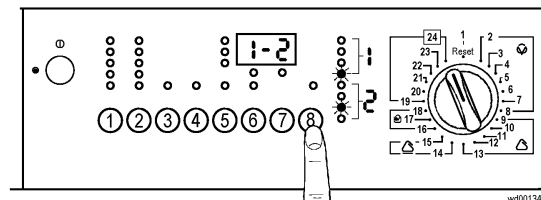

when all 16 digits have been entered, check that the code is correct, then memorize the code by pressing the START/PAUSE button and one of the option buttons at the same time; these buttons should be held down until the buzzer (if featured) sounds.

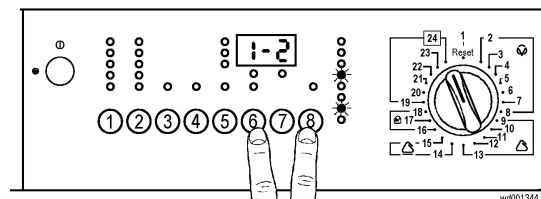

4 sec.

If the configuration is not entered correctly, the wash cycle will not start when the START button is pressed.

*When configuration has been completed, perform the diagnostics routine in order to check that the appliance functions correctly. In case of an error, the display window will show error code **E93**.*

CONFIGURATION CODE

The configuration code (16 alphanumeric digits) shown on a label affixed to the casing of the main PCB and in the Service Notes describing the various models.

It is advisable to note the configuration code on the casing of the new PCB fitted to the washing machine.

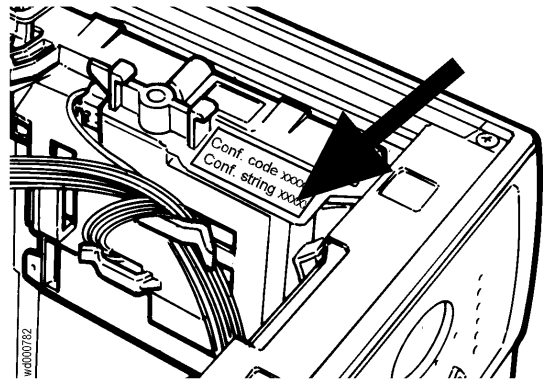

READING THE CONFIGURATION CODE

The configuration code is shown, one character at a time, on the display (if featured) or on the washing phase display LEDs.

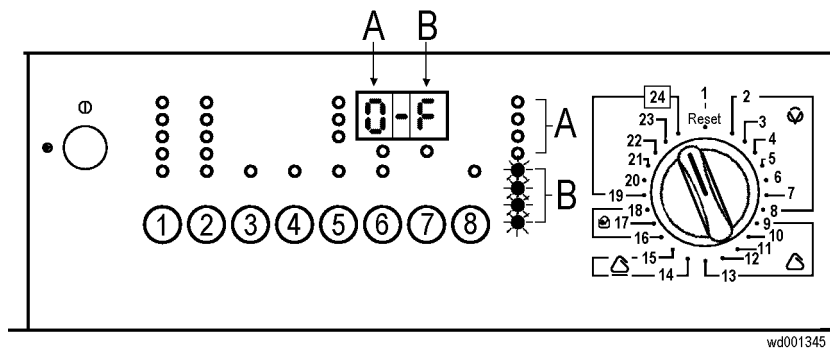

A = The first digit shown on the display (if featured) indicates the **position** of the value to be entered. The same information is also displayed in binary format on the first four washing phase LEDs. To **read** the various positions, press one of the wash cycle option buttons (the first position displayed is "0").

B = The last digit on the display (if featured) indicates the **value** of the configuration character to be entered in a given position. The same information is also displayed in binary format on the second set of four washing phase LEDs. To **modify** the value of the character displayed, press the START/PAUSE button.

BINARY CODES

The table below can be used to convert the binary code shown by the LEDs into the corresponding letter or decimal number.

0	1	2	3	4	5	6	7	8	9	10	11	12	13	14	15
										A	b	C	d	E	F
<input type="checkbox"/>	<input type="checkbox"/>	<input type="checkbox"/>	<input type="checkbox"/>	<input type="checkbox"/>	<input type="checkbox"/>	<input type="checkbox"/>	<input type="checkbox"/>	<input type="checkbox"/>	<input type="checkbox"/>	<input type="checkbox"/>	<input type="checkbox"/>	<input type="checkbox"/>	<input type="checkbox"/>	<input type="checkbox"/>	<input type="checkbox"/>
<input type="checkbox"/>	<input type="checkbox"/>	<input type="checkbox"/>	<input type="checkbox"/>	<input type="checkbox"/>	<input type="checkbox"/>	<input type="checkbox"/>	<input type="checkbox"/>	<input type="checkbox"/>	<input type="checkbox"/>	<input type="checkbox"/>	<input type="checkbox"/>	<input type="checkbox"/>	<input type="checkbox"/>	<input type="checkbox"/>	<input type="checkbox"/>
<input type="checkbox"/>	<input type="checkbox"/>	<input type="checkbox"/>	<input type="checkbox"/>	<input type="checkbox"/>	<input type="checkbox"/>	<input type="checkbox"/>	<input type="checkbox"/>	<input type="checkbox"/>	<input type="checkbox"/>	<input type="checkbox"/>	<input type="checkbox"/>	<input type="checkbox"/>	<input type="checkbox"/>	<input type="checkbox"/>	<input type="checkbox"/>
<input type="checkbox"/>	<input type="checkbox"/>	<input type="checkbox"/>	<input type="checkbox"/>	<input type="checkbox"/>	<input type="checkbox"/>	<input type="checkbox"/>	<input type="checkbox"/>	<input type="checkbox"/>	<input type="checkbox"/>	<input type="checkbox"/>	<input type="checkbox"/>	<input type="checkbox"/>	<input type="checkbox"/>	<input type="checkbox"/>	<input type="checkbox"/>

- LED off
- LED lit

EXAMPLES OF CONFIGURATION

Configuration code: **A2A7808080E691F2**

POSITION:	0	1	2	3	4	5	6	7	8	9	10	11	12	13	14	15
											(A)	(B)	(C)	(D)	(E)	(F)
	↓	↓	↓	↓	↓	↓	↓	↓	↓	↓	↓	↓	↓	↓	↓	↓
VALUE:	A	2	A	7	8	0	8	0	8	0	E	6	9	1	F	2

TABLE OF CYCLE PHASE LEDS

On models not featuring the display window, it is advisable, before beginning the configuration procedure, to convert the digits of the configuration code into binary format. To do this, prepare a table of the values to be entered, which will be displayed by the second group (B) of washing phase LEDs (the positions, indicated by the second group of 4 LEDs, are not modified).

POSITION	0	1	2	3	4	5	6	7	8	9	10	11	12	13	14	15
											A	b	C	d	E	F
	<input type="checkbox"/>	<input type="checkbox"/>	<input type="checkbox"/>	<input type="checkbox"/>	<input type="checkbox"/>	<input type="checkbox"/>	<input type="checkbox"/>	<input type="checkbox"/>	<input type="checkbox"/>	<input type="checkbox"/>	<input type="checkbox"/>	<input type="checkbox"/>	<input type="checkbox"/>	<input type="checkbox"/>	<input type="checkbox"/>	<input type="checkbox"/>
	<input type="checkbox"/>	<input type="checkbox"/>	<input type="checkbox"/>	<input type="checkbox"/>	<input type="checkbox"/>	<input type="checkbox"/>	<input type="checkbox"/>	<input type="checkbox"/>	<input type="checkbox"/>	<input type="checkbox"/>	<input type="checkbox"/>	<input type="checkbox"/>	<input type="checkbox"/>	<input type="checkbox"/>	<input type="checkbox"/>	<input type="checkbox"/>
	<input type="checkbox"/>	<input type="checkbox"/>	<input type="checkbox"/>	<input type="checkbox"/>	<input type="checkbox"/>	<input type="checkbox"/>	<input type="checkbox"/>	<input type="checkbox"/>	<input type="checkbox"/>	<input type="checkbox"/>	<input type="checkbox"/>	<input type="checkbox"/>	<input type="checkbox"/>	<input type="checkbox"/>	<input type="checkbox"/>	<input type="checkbox"/>
	<input type="checkbox"/>	<input type="checkbox"/>	<input type="checkbox"/>	<input type="checkbox"/>	<input type="checkbox"/>	<input type="checkbox"/>	<input type="checkbox"/>	<input type="checkbox"/>	<input type="checkbox"/>	<input type="checkbox"/>	<input type="checkbox"/>	<input type="checkbox"/>	<input type="checkbox"/>	<input type="checkbox"/>	<input type="checkbox"/>	<input type="checkbox"/>
VALUE	<input type="checkbox"/>	<input type="checkbox"/>	<input type="checkbox"/>	<input type="checkbox"/>	<input type="checkbox"/>	<input type="checkbox"/>	<input type="checkbox"/>	<input type="checkbox"/>	<input type="checkbox"/>	<input type="checkbox"/>	<input type="checkbox"/>	<input type="checkbox"/>	<input type="checkbox"/>	<input type="checkbox"/>	<input type="checkbox"/>	<input type="checkbox"/>
	<input type="checkbox"/>	<input type="checkbox"/>	<input type="checkbox"/>	<input type="checkbox"/>	<input type="checkbox"/>	<input type="checkbox"/>	<input type="checkbox"/>	<input type="checkbox"/>	<input type="checkbox"/>	<input type="checkbox"/>	<input type="checkbox"/>	<input type="checkbox"/>	<input type="checkbox"/>	<input type="checkbox"/>	<input type="checkbox"/>	<input type="checkbox"/>
	<input type="checkbox"/>	<input type="checkbox"/>	<input type="checkbox"/>	<input type="checkbox"/>	<input type="checkbox"/>	<input type="checkbox"/>	<input type="checkbox"/>	<input type="checkbox"/>	<input type="checkbox"/>	<input type="checkbox"/>	<input type="checkbox"/>	<input type="checkbox"/>	<input type="checkbox"/>	<input type="checkbox"/>	<input type="checkbox"/>	<input type="checkbox"/>
	<input type="checkbox"/>	<input type="checkbox"/>	<input type="checkbox"/>	<input type="checkbox"/>	<input type="checkbox"/>	<input type="checkbox"/>	<input type="checkbox"/>	<input type="checkbox"/>	<input type="checkbox"/>	<input type="checkbox"/>	<input type="checkbox"/>	<input type="checkbox"/>	<input type="checkbox"/>	<input type="checkbox"/>	<input type="checkbox"/>	<input type="checkbox"/>
	A	2	A	7	8	0	8	0	8	0	E	6	9	1	F	2

CONFIGURATION

1. Access the diagnostics system.
2. Turn the programme selector counter-clockwise by one position.
3. Press the START/PAUSE button sequentially to enter the letter **A** in position **0**. If the appliance features a display window, this will show **0-A**; if not, the wash cycle LEDs should light as shown in column 0 of the table (i.e. the fifth and seventh LEDs).
4. Press one of the option buttons (with the exception of START/PAUSE) to pass to the second position, and enter **2** by pressing START/PAUSE. The display should now show **1-2**, and the LEDs should light as shown in column 1 of the table (fourth and seventh).
5. Repeat this procedure to enter the remaining configuration digits. When all the digits have been entered, press one of the option buttons (with the exception of START/PAUSE) to check that the configuration code is correct.
6. Memorize the configuration code by pressing START/PAUSE and one of the option buttons at the same time for at least 4 seconds, so that the configuration code is memorized by the main PCB.

EXITING THE DIAGNOSTICS CYCLE

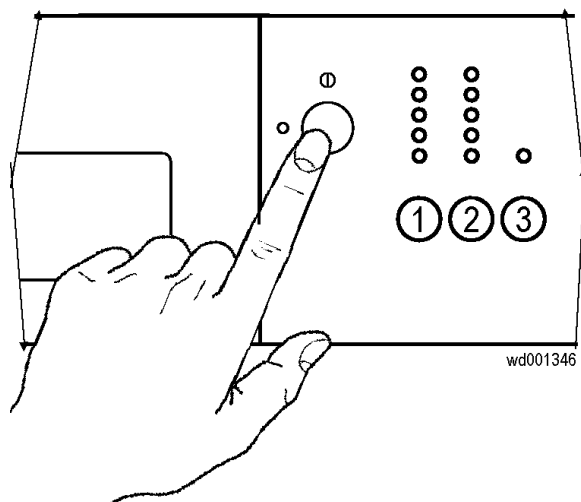

To exit the diagnostics cycle, switch the appliance off, on, and then off again.

BASIC CIRCUIT DIAGRAM (AC motor)

wd001131

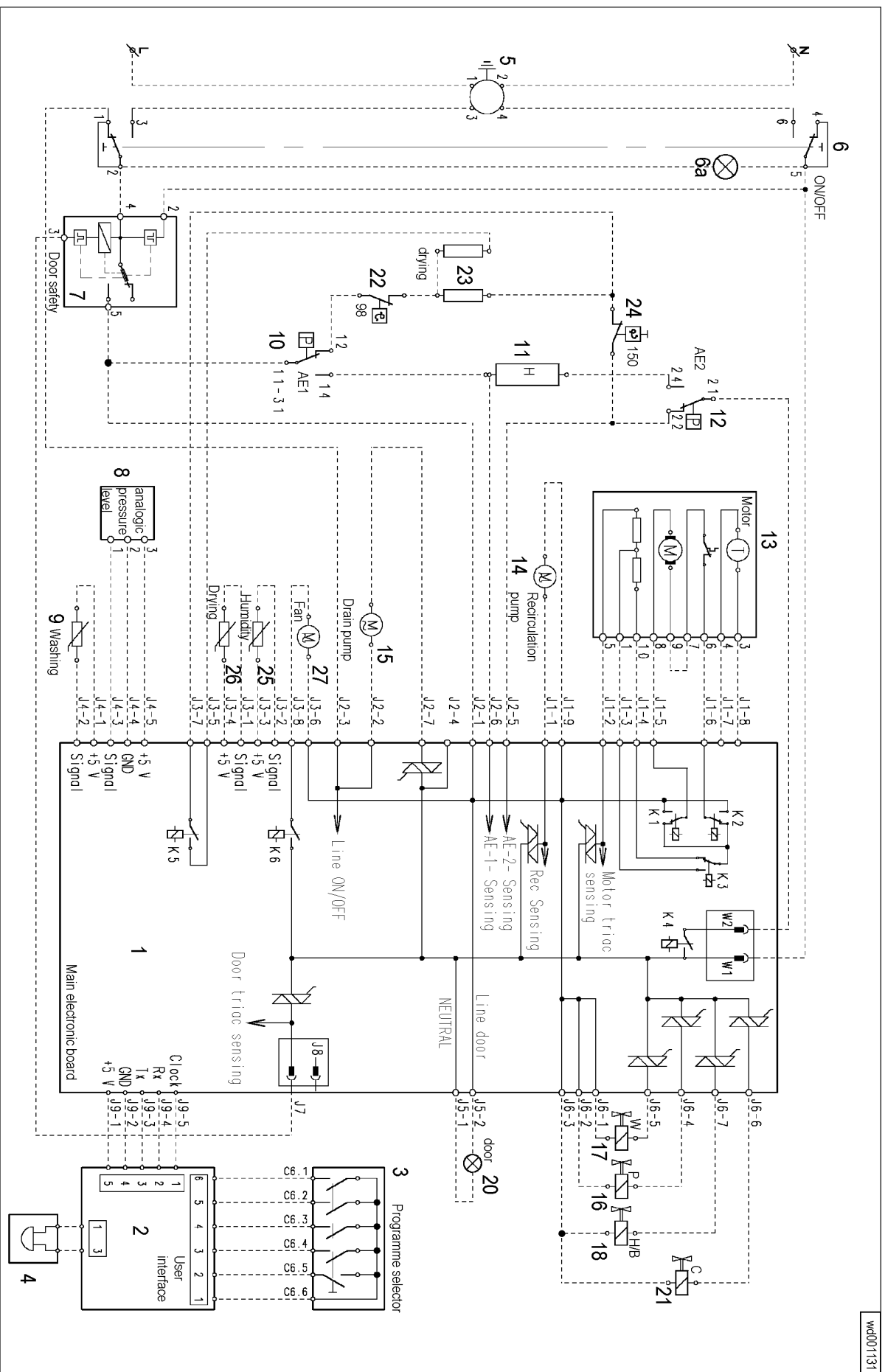

BASIC CIRCUIT DIAGRAM (DC motor)

WD001132

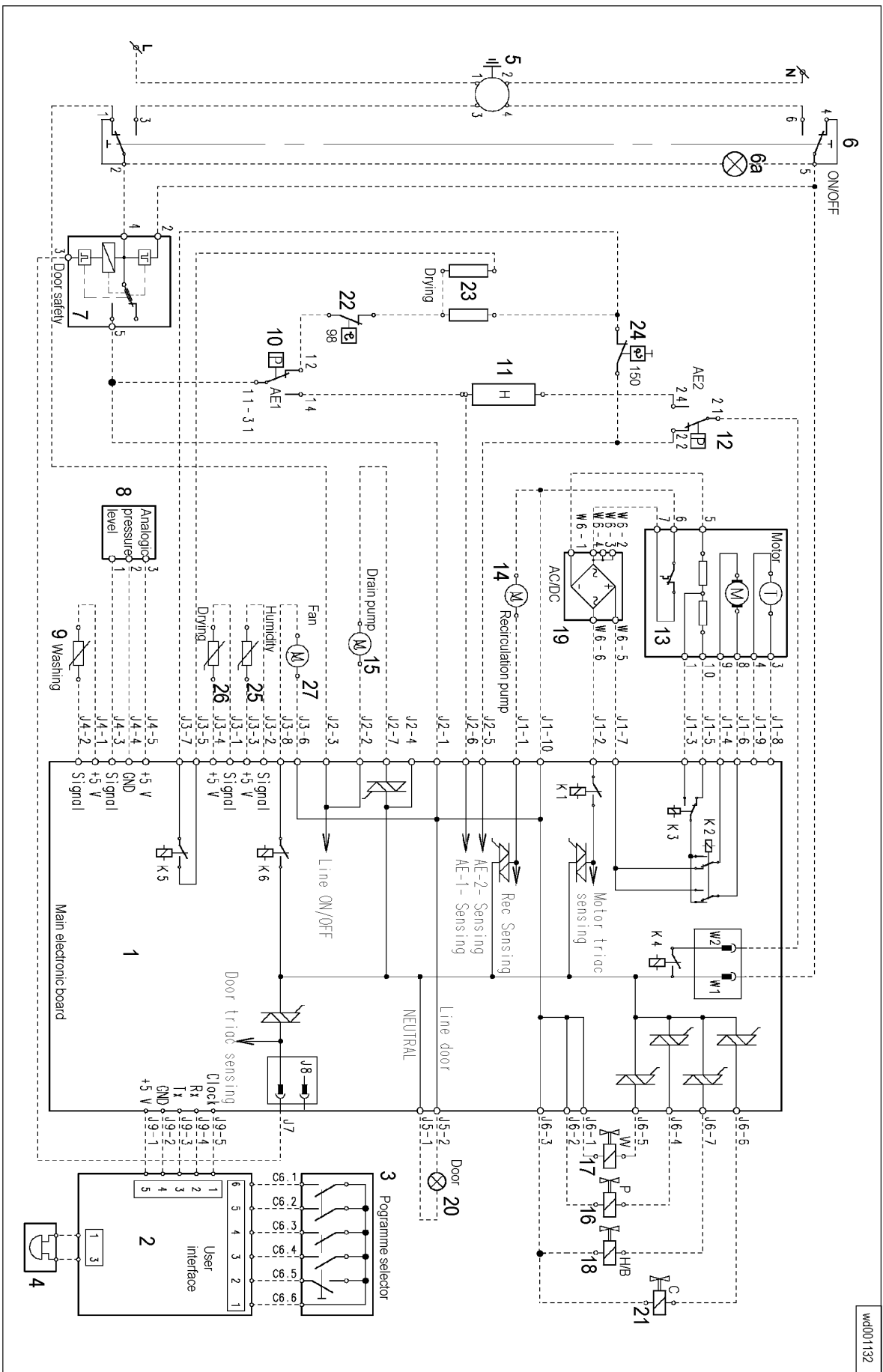

Key to circuit diagram

- | | |
|---|--|
| 1. Main PCB | |
| 2. Control/display board | |
| 3. Programme selector | |
| 4. Buzzer (certain models only) | |
| 5. Anti-interference filter | |
| 6. ON/OFF button | |
| 6a. Pilot lamp | |
| 7. Door interlock | |
| 8. Electronic pressure switch | |
| 9. NTC temperature sensor (washing) | |
| 10. Anti-boiling pressure switch 1 | |
| 11. Heating element (washing) | |
| 13. Motor | |
| 12. Anti-boiling pressure switch 2 | |
| 14. Recirculation pump (Jetssystem models) | |
| 15. Drain pump | |
| 16. Pre-wash solenoid | |
| 17. Wash solenoid | |
| 18. Bleach solenoid or hot water solenoid (certain models only) | |
| 19. AC/DC converter (certain models only) | |
| 20. Door lamp | |
| | 21. Condensation solenoid |
| | 22. Safety thermostat |
| | 23. Heating element (drying) |
| | 24. Manual-reset safety thermostat |
| | 25. NTC temperature sensor (drying time control) |
| | 26. NTC temperature sensor (drying) |
| | 27. Fan motor |

Washer/dryers only

NOTES FOR THE REPLACEMENT OF THE CONTROL DISPLAY/BOARD

When replacing the control/display board, before fitting the new part, cut the 5 plastic hooks placed on the PCB casing (see figure).

