

Frontloading  
washing machines

**EWM1000plus  
NEXXT**

© Electrolux  
Muggenhofer Straße 135  
D-90429 Nürnberg  
Germany

Publ.-Nr.:  
**599 51 86-29**  
685  
EN

Fax +49 (0)911 323 1022

DGS-TDS-N  
Edition: 11.2003

## Table of contents

1.	Operating elements/panel .....	4
1.1	One button input philosophy .....	4
2.	Washing programmes and options .....	5
2.1	Programmes .....	5
2.2	Options .....	6
2.3	Description of options .....	7
3.	Washing programmes .....	9
3.1	Normal (consumer) cotton/linen-cycles .....	9
3.2	Cotton/Linen cycles: 90 Eco, 60 - 40/50 "energy label" .....	10
3.3	Normal (consumer) synthetics-cycles .....	11
3.4	Delicates-cycles .....	12
3.5	Wool-cycles .....	13
3.6	Hand-wash cycle .....	13
4.	Control of water level in tub .....	14
4.1	Profile of cottons/linen 60°C eco / energy label cycle .....	15
4.2	Profiles of cottons/linen 60°C cycles .....	15
4.3	Profile of cottons/linen 95°C .....	16
4.4	Profile of cottons/linen 40°C .....	16
4.5	Profile of delicates 30°C .....	17
4.6	Profile of wool 40°C .....	17
5.	Drum movements .....	18
6.	Spinning profiles .....	19
7.	Technical characteristics .....	21
7.1	EWM1000plus electronic control .....	21
7.1.1	Functions of the circuit board .....	21
7.1.2	Contacts of the circuit board .....	21
7.2.	Programme-selector .....	22
7.3	The doorlock .....	23
7.3.1	Thermal doorlock .....	23
7.3.2	Instantaneous doorlock (IDOLO) .....	23
7.4	Pressure switch .....	24
7.5	Water fill system .....	25
7.6	Anti-flooding-device .....	25
7.7	Heating element .....	26
7.8	NTC-sensor .....	26
7.9	Drain pump .....	27
7.10	Motor .....	27
7.11	Anti-foam control system .....	28
8.	Fast Unbalance-Control-System (FUCS) .....	27
8.1.	Examples of operation of the unbalancing control function .....	27
9.	Service test programme .....	29
10	Alarms .....	30
10.1	User alarm display .....	30
10.1.1	Alarms displayed during normal operation .....	30
10.2	Reading the alarm codes .....	31
10.2.1	Displaying the alarm .....	31
10.2.2	Operation of alarms during diagnostics .....	31
10.3	Rapid reading of alarm codes .....	32
10.4	Cancelling the last alarm .....	32
10.5	Table of alarm codes .....	33
11.	Demo-mode .....	35
11.1	Access to demo-mode .....	35
11.2	Exiting demo-mode .....	35
13.	Wiring .....	36
14.	Circuit diagram .....	38
15.	Legend .....	40

#### General characteristics:

- Electronic control system EWM1000 PLUS
- 21-position programme selector with integrated main-switch
- Max. 9 pushbuttons, 26 LEDs
- Multidisplay
- 3-level pressure switch
- Traditional washing-system with eco-ball
- Anti-foam control
- Anti-unbalancing system (FUCS)
- Spin speed up to 1600 rpm (depends on machine-configuration)
- 2 or 3 solenoid valves
- 3 or 4 fill-in compartments
- Carboran-tub with 5kg (G20) or 6kg (G22) drum
- Traditional (PTC) or instantaneous (IDOLO) doorlock-device
- Heating element 1950W, integrated in the tub
- Temperature control with NTC
- Power supply 220/240V, 50/60Hz (depends on machine-configuration)

# 1. Operating elements/panel

## 1.1 One button input philosophy

- 21-position programme selector with integrated main-switch
- Max. 9 pushbuttons
- Max. 29 LEDs
- Multidisplay

The various positions of the selector may be configured to perform different washing programmes. In the position 0 (off), the appliance is switched off and the current programme is cancelled. For each programme, the compatible options and other parameters are defined.

The washing programmes, the functions of the selector knob and the various push buttons vary according to the model, since these are determined by the configuration of the appliance.

Configuration-example:

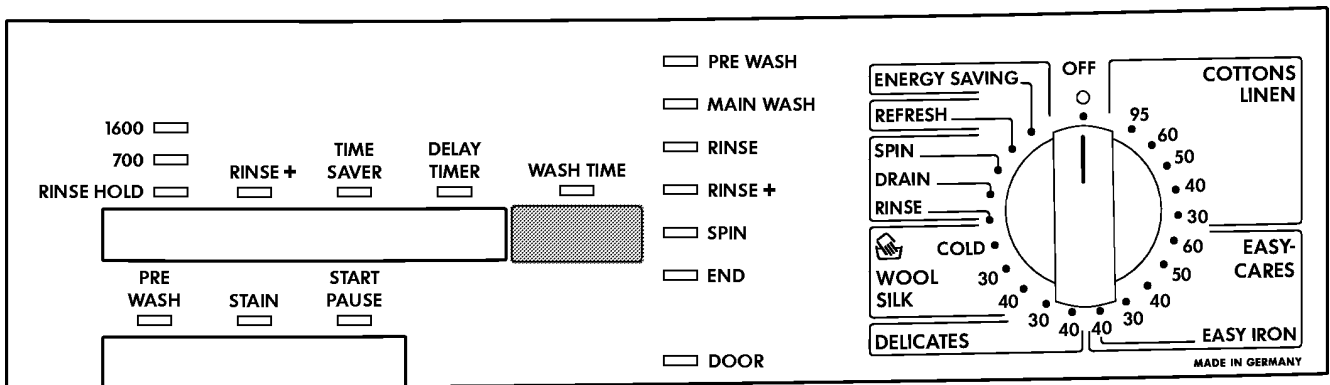

## 2. Washingprogrammes and options

### 2.1 Programmes

The washing programmes can be configured. The basic programmes are listed in the table below.

Programme		Temperature (°C)	Number of rinses	Final spin (rpm)
Cotton	90	85	3	450/650/850/1000/1200/ 1300/1400/1600
	90E	67	2	
	60	60	3	
	60E	50	2	
	50	50	3	
	50/40E	44	2	
	40	42	3	
	30	30		
cold	20			
Synthetic fabrics	60	60	3	Max. 900
	60/50E	42		
	50	50		
	40	40		
	30	30		
	cold	20		
Delicates	40	40	3	450/700
	30	30		
	cold	20		
Wool	40	40	3	Max. 1000
	30	35		
	cold	20		
Hand-wash	40	40	3	Max. 1000
	30	35		
	cold	20		
<b>Soak</b>		30/20	----	----
<b>Rinses</b>		----	3	Max. 1600
<b>Delicate rinses</b>		----	3	Max. 700
<b>Conditioner</b>		----	1	Max. 1600
<b>Drain</b>		----	----	----
<b>Spin</b>		----	----	Max. 1600
<b>Delicate spin</b>		----	----	Max. 700
<b>Mini</b>		30	2	Max. 1000

## 2.2 Options

The table below lists the possible options for the washing programmes, the compatibility of the various options and with the cycle, and when it is possible to select or modify the options.

The options can be selected in different ways:

- using the programme selector: in this case, the options are configured as special programmes.
- using the pushbuttons

		OPTIONS												
		Rinse-hold	Night cycle	Pre-wash	Stains	Short (Daily)	Very short	Economy	Super-rinse	Bleach	Half-load	Easy-iron	Reduced spin speed	
Compatibility with PROGRAMMES	Cotton	90°C	x	x	x	x	x	x	x	x	x	x	x	x
		60°C	x	x	x	x	x	x	x	x	x	x	x	x
		50°C	x	x	x	x	x	x	x	x	x	x	x	x
		40°C	x	x	x	x	x	x	x	x	x	x	x	x
		30°C	x	x	x		x	x		x	x	x	x	x
		cold	x	x	x		x	x		x	x	x	x	x
	Synthetic fabrics	60°C	x	x	x	x	x	x	x				x	x
		50°C	x	x	x	x	x	x	x				x	x
		40°C	x	x	x	x	x	x	x				x	x
		30°C	x	x	x		x	x		x			x	x
		cold	x	x	x		x	x		x			x	x
	Delicates	40°C	x	x	x			x		x				x
		30°C	x	x	x			x		x				x
		cold	x	x	x			x		x				x
	Wool / Hand washing	40°C	x	x										x
		30°C	x	x										x
		cold	x	x										x
	Soak													x
	Rinses		x	x						x	x	x		x
	Delicate rinses		x	x						x				x
Conditioner		x	x										x	
Drain														
Spin													x	
Delicate spin													x	
Compatibility with OPTIONS	Rinse-Hold			x	x	x	x	x	x	x	x	x		
	Night-time cycle			x	x	x	x	x	x	x	x	x		
	Pre-wash	x	x			x	x	x	x		x	x	x	
	Stains	x	x			x	x	x	x		x	x	x	
	Very short	x	x	x	x				x	x	x	x	x	
	Short (Daily)	x	x	x	x				x	x	x	x	x	
	Economy	x	x	x	x				x	x	x	x	x	
	Super rinse	x	x	x	x	x	x	x		x	x	x	x	
	Bleach	x	x			x	x	x	x		x	x	x	
	Half-load	x	x	x	x	x	x	x	x	x		x	x	
	Easy-iron	x	x	x	x	x	x	x	x	x	x		x	
	Reduced spin speed			x	x	x	x	x	x	x	x	x		
	Phases in which selection or modification are possible	Selection	x	x	x	x	x	x	x	x	x	x	x	x
Pre-wash		x	x		x	x	x	x	x	x	x	x	x	
Wash		x	x		x	x	x	x	x	x	x	x	x	
Rinses		x							x	x	x	x	x	
Spin												x	x	

## 2.3 Description of options

### - **Night-cycle**

- Eliminates all spin phases and adds three rinses in COTTON cycles and two rinses in SYNTHETICS cycles.
- Stops the appliance with water in the tub before the final rinse.
- Switches off the buzzer (if configured).

### - **Rinse-hold**

- Stops the appliance with water in the tub before the final spin cycle.
- To drain the water select a drain or spin cycle.

### - **Pre-wash**

- Adds a pre-wash phase at the start of the cycle with water heating to 30°C (or cold, if selected).
- In COTTON and SYNTHETICS cycles, performs a short spin before passing to the washing phase.
- This option cannot be selected for WOOL and HAND-WASH cycles.

### - **Soak**

- Adds a pre-wash phase (30 min. duration with wool cycle movement) at the start of the cycle with water heating at 30°C (or cold, if selected).
- In COTTON and SYNTHETICS cycles, performs a short spin (impulse) before passing to the washing phase.
- Together with the delayed start option it is possible to select a soak time from 30 minutes up to 10 hours.
- This option cannot be selected for WOOL and HAND-WASH cycles.

### - **Stains**

- Adds a 5-minute motor movement phase after heating to 40°C.
- Ducts water to the pre-wash/stains compartment in order to introduce the special stain-removal product.
- This option cannot be selected for DELICATES, WOOL and HAND-WASH cycles.

### - **Short (Daily)**

- Modifies the structure of the washes in the COTTON and SYNTHETICS programmes in order to obtain good washing performance with a very short cycle (optimization for small loads).

### - **Very short**

- Modifies the structure of the COTTON, SYNTHETICS and DELICATES programmes in order to obtain short washing times (optimization for small or lightly-soiled loads).
- Reduces the number of rinse cycles (one less).
- Increases the water level in the remaining two rinse cycles.

### - **Intensive**

- It changes the washing phase adding 10 min. of normal movement in the cotton programme.

- **Economy / Energy label**

- Modifies the structure of the COTTON 40-60 and SYNTHETICS 50/60 cycles in order to reduce energy consumption.
- Reduces the washing temperature.
- Increases the duration of the wash phase.

- **Sensitive**

- Adds a rinse in the COTTON - SYNTHETIC FABRICS.
- During the cotton cycles the movements pass from vigorous to normal.
- Eliminates the intermediate spins except from the last two which are reduced.

- **Super-rinse**

- Adds two rinses in the COTTON, SYNTHETICS and DELICATES cycles.
- Eliminates the intermediate spin cycles, with the exception of the final rinse, which is reduced to 450 rpm.

- **Bleach**

- Ducts water through the bleach compartment at the beginning of the first rinse in COTTON cycles.
- Pre-wash possible only where there are three solenoids.
- In models with two solenoids the bleach is not compatible with the pre-wash option.

- **Easy-Iron**

- In COTTON-cycles:

- adds three rinse cycles
- eliminates the intermediate spin cycles
- performs an impulse spin phase
- adds an "untangling" phase after the spin cycle

- In SYNTHETICS-cycles:

- reduces the heating temperature in 50/60° cycles to 40°C
- increases the washing time
- prolongs the cooling phase at the end of the washing phase
- adds one rinse
- adds an "untangling" phase after the impulse spin cycle

- **Reduced spin speed**

- Reduces the speed of all spins as shown in the table:

Maximum spin speed (rpm)	600	700	800	900	1000	1100	1200	1300	1400	1500	1600
Reduction for COTTON (rpm)	450	450	450	450	500	550	600	650	700	750	800
Reduction for ALL OTHER CYCLES (rpm)	450	450	450	450	450	450	450	450	450	450	450

- **No spin**

- Eliminates all the spin phases.
- If selected, three rinses are added in the COTTON cycle and one in the SYNTHETICS cycle.



### 3. Washing programmes

#### 3.1 Normal (consumer) cotton / linen-cycles: cold - 30°C - 40°C - 50°C - 60°C - 90°C (without options)

Phase	N.	Function	Time/ control	Movement	Heat. °C	Notes	
Delay		Delayed start	Delay time	No Mov			
Prewash	0	Drain	VAE + 2" + 6" pause	No Mov			
	1	Water fill	P1 + QPW1 (*)	D55 from full			
	2	Cold wash	5'			Refill: P1	
	3	Water fill	QPW2 (*)	D55	30	Cold = 20°C	
	4	Heating	T				
	5	Maintenance	10'				
	6	Drain + spin	VAE + 14" + 4,5'	C0		300/450/650 rpm	
Wash		7 Cotton water fill	P1 + Qh1 (*)	N55 from full			
		8 Cold wash	10'			Refill: P1+Qn1	
	Stains	9	Heating	T	N55	40	Only with "stains" option
		10	Maintenance	5'			
		11	"Stains" water fill	Qs (*)			
		12	Cotton heating	T	N55	20/30/40/ 60/87	
		13	Maintenance	4'(87°)/5'(20-40°) /10'(60°)	N55		
		14	Cotton heating	T	E55	30/40/60/ 87	
		15	Maintenance	14'(87°)/35'(20-40°) /20'(60°)	E55		
	Cooling	16	Cooling water fill	Qc (*)	D55		Only if >67°C
		17	Movement	2'			
		18	Drain	VAE + 14"	No Mov		
		19	Drain + spin	5'	C1		450/650/850 rpm
Rinses	1st rinse	20	Cotton water fill	P1	N 55 from full		
		21	Movement	5'			Refill : P1+Qn1
		22	Drain	VAE + 15"		No Mov	
		23	Drain + spin	5'	C2		450/650/850/1000rp
	2nd rinse	24	Cotton water fill	P1+ Qn2 (*)	N 55 from full		
		25	Movement	5'			Refill: P1+Qne
		26	Drain	VAE + 15"		No Mov	
		27	Drain + spin	5'	C2		450/650/850/1000rm
	Last rinse (softener)	28	Cotton water fill	P1	N 55 from full		
		29	Movement	30"			
		30	Time water fill	Qn3			
		31	Movement	8'			
32		Drain	VAE + 14"	No Mov			
33		Drain + spin	9'	COT_CF		450/650/850/1000/ 1200/1400 rpm	
	34	Detach movement	1'	N55			

#### Notes:

P1 time needed to 1<sup>st</sup> level water fill

(\*) time water fills are changeable and calculated by the electronic on the basis of the delivery rate (see specific table)

T time needed to heat the water at the set temperature

" seconds

' minutes

VAE time needed to drain the water till "empty" position of anti- boiling (safety heater) pressure switch

### 3.2 Cotton/linen cycles: 90 Eco, 60 - 40/50 "energy label" (without options)

Phase		N.	Function	Time/ Control	Movement	Heat. °C	Notes	
Delay			Delayed start	Delay time	No Mov			
Prewash		0	Drain	VAE + 2" + 6" pause	No Mov			
		1	Water fill	P1 + QPW1 (*)	D55 full		Refill: P1	
		2	Cold wash	5'				
		3	Water fill	QPW2 (*)	D55	30		
		4	Heating	T				
		5	Maintenance	10'				
		6	Drain + spin	VAE + 14" + 4,5'	C0		300/450/650 rpm	
Wash		7	Cotton water fill	P1 + Qe (*)	N55 from full		Refill: P1+Qwe	
		8	Cold wash	10'				
		9	Cotton heating	T	N55	67/53/44	E50 (G19-40/50°)	
		10	Maintenance	10'(67°) / 5'(50°) / 30'(40°)	E55			
		11	Cotton heating	T	E55	67/53/44	E50 (G19-40/50°)	
		12	Maintenance	30'(67°) / 35'(50°-40°)	E55		20' (G19-40°)	
		13	Drain	VAE + 14"	No Mov			
		14	Drain + spin	5'	C1		450/650/850 rpm	
Rinses	1st rinse	15	Cotton water fill	P1 (C1=850 g/) P1+Qn2 (C1<850 g/)	N 55 from full		Refill: P1+Qne	
		16	Movement	5'				
		17	Drain	VAE + 15"	No Mov			
	18	Drain + spin	5'	C2		450/650/850/1000rm		
	2nd rinse	19	Cotton water fill	P1 + Qn2 (*)	N 55 from full		Refill: P1+Qne	
		20	Movement	5'				
		21	Drain	VAE + 15"	No Mov			
			22	Drain + spin	5'	C2		450/650/850/1000rm
	Last rinse (softener)		23	Cotton water fill	P1	N 55 from full		
			24	Movement	30"			
			25	Time water fill	Qn3			
26			Movement	8'				
27			Drain	VAE + 14"	No Mov			
28			Drain + spin	9'	COT_CF		450/650/850/1000/ 1200/1400 rpm	
		29	Detach movement	1'	N55			

#### Notes:

P1 time needed to 1<sup>st</sup> level water fill

(\*) time water fills are changeable and calculated by the electronic on the basis of the delivery rate (see specific table)

T time needed to heat the water at the set temperature

" seconds

' minutes

VAE time needed to drain the water till "empty" position of anti- boiling (safety heater) pressure switch

**3.3 Normal (consumer) synthetics-cycles: cold - 30°C - 40°C - 50°C - 60°C (without options)**

Phase		N.	Function	Time/ control	Movement	Heat. °C	Notes	
Delay			Delayed time	Delay time	No Mov			
Prewash		0	Drain	VAE + 2" + 6" pause	No Mov			
		1	Water fill	P1 + QPW1 (*)	D 55 from full			
		2	Cold wash	5'			Refill: P1	
		3	Water fill	QPW2 (*)	D 55	30	Cold = 20°C	
		4	Heating	T				
		5	Maintenance	5'				
	6	Drain + spin	VAE + 15" + 4,5'	C0		300/450/650 rpm		
Wash		7	Synthetics water fill	P1 + Qsy (*)	N 55 from full			
		8	Cold wash	10'			Refill: P1+Qy1	
	Stains		9	Heating	T	N 55	40	Only with "stains" option
			10	Maintenance	5'			
			11	"Stains" water fill	Qs (*)			
			12	Heating	T	N55 for T>40° E55 per T< / = 40°	20/30/40/ 50/60	Economy = 42°C
			13	Maintenance	10'			
			14	Heating	T	E55	20/30/40/ 50/60	Economy = 42°C
			15	Maintenance	15'			
	Cooling		16	Cooling water fill	Qc (*)	N55		
			17	Movement	1'			
		18	Drain	VAE	No Mov			
		19	Drain	1'	D55			
Rinses	1st rinse	20	Water fill	P1+ Qyr1 (*)	E55 from full			
		21	Movement	3'			Refill: P1	
		22	Drain	VAE	No Movement			
	2nd rinse	23	Drain	1'	D55			
		24	Water fill	P1+ Qyr2 (*)	E 55 from full			
		25	Movement	3'			Refill: P1	
		26	Drain	VAE	No Mov			
		27	Drain	1'	D55			
	28	Drain + spin	4'	C0		300/450/650 rpm		
	Last rinse (softener)	29	Water fill	P1	E55 from full			
		30	Movement	30"				
31		Time water fill	Qyr3					
32		Movement	5'			Refill: P1		
33		Drain	VAE + 14"	No Mov				
34		Drain + spin	4,5'	SYN_CF		(max. 900rpm)		
35		Detach movement	1'	N55		Not for Economy		

**Notes:**

P1 time needed to 1<sup>st</sup> level water fill

(\*) time water fills are changeable and calculated by the electronic on the basis of the delivery rate (see specific table)

T time needed to heat the water at the set temperature

" seconds

' minutes

VAE time needed to drain the water till "empty" position of anti- boiling (safety heater) pressure switch

### 3.4 Delicates-cycles: cold - 30°C - 40°C without options

Phase		N.	Function	Time/ control	Movement	Heat. °C	Notes	
Delay			Delayed start	Delay time	No Mov			
Prewash		0	Drain	VAE + 2" + 6" pause	No Mov			
		1	Water fill	P1 + QPW1 (*)	D55 from full			
		2	Cold wash	5'			Refill: P1	
		3	Water fill	QPW2 (*)	D55			
		4	Heating	T		30	Cold = 20°C	
		5	Maintenance	3'				
		6	Drain	VAE + 15"	No Mov			
Wash		7	Delicates water fill	P1 + Qdw1 (*)	D55 from full			
		8	Cold wash	1'	D55		Refill: P1+Qdw2	
		9	Heating	T	D55	20/30/40		
		10	Maintenance	10'				
		11	Heating	T		20/30/40		
				12	Maintenance	10'		
				13	Drain	VAE	No Mov	
		14	Drain	1'	D55			
Rinses	1st rinse	15	Water fill	P1+ Qrd1 (*)	D55 from full			
		16	Movement	5'	D55		Refill: P1	
		17	Drain	VAE	No Mov			
		18	Drain	1'	D55			
	2nd rinse	19	Water fill	P1+ Qrd1 (*)	D55 from full			
		20	Movement	5'	D55		Refill: P1	
		21	Drain	VAE	No Mov			
		22	Drain	1'	D55			
	Last rinse (softener)	23	Water fill	P1	D55 from full			
		24	Movement	30"				
		25	Time water fill	Qrd2 (*)				
26		Movement	3'		Refill: P1			
27		Drain	VAE	No Mov				
28		Drain + spin	3,8'	DEL_CF		(450/700rpm)		
29		Detach movement	1'	N55				

#### Notes:

P1 time needed to 1<sup>st</sup> level water fill

(\*) time water fills are changeable and calculated by the electronic on the basis of the delivery rate (see specific table)

T time needed to heat the water at the set temperature

" seconds

' minutes

VAE time needed to drain the water till "empty" position of anti- boiling (safety heater) pressure switch

### 3.5 Wool-cycles: cold - 30°C - 40°C

Phase	N.	Function	Time/ control	Movement	Heat. °C	Notes	
Delay		Delayed time	Delay time	No Mov			
Wash	0	Drain	VAE + 2" + 6" pause	No Mov			
	1	Wool water fill	P1 + Qwo (*)	Pwl_1	20/35/40	Refill:P1+Qwo1	
	2	Cold wash	1'				
	3	Heating	T				
	4	Maintenance	14'				
	5	Drain	VAE+14"	No Mov			
Rinses	1st rinse	6	Water fill	P1	No Mov		
		7	Time water fill	Qwor1 (*)	Pwl_1	Refill:P1	
		8	Movement	3'			
	9	Drain	VAE+14"				
	2 <sup>nd</sup> rinse	10	Water fill	P1	No Mov		
		11	Time water fill	Qwor1 (*)	Pwl_1	Refill:P1	
		12	Movement	3'			
	13	Drain	VAE+14"	No Mov			
	Last rinse (softener)	14	Water fill	P1	No Mov		
		15	Movement	30"	Pwl_1	Refill:P1	
		16	Time water fill	Qwor2 (*)			
		17	Movement	5'			
18		Drain	VAE+14"	No Mov			
19	Drain + spin	3,5'	WOOL_CF		(max. 1000rpm)		

### 3.6 Hand-wash cycle: cold - 30° C - 40°C

Phase	N.	Function	Time/ control	Movement	Heat. °C	Notes	
Delay		Delayed start	Delay time	No Mov			
Wash	0	Drain	VAE + 2" + 6" pause	No Mov			
	1	Wool water fill	P1 + Qwh (*)	Pwl_4	20/35/40	Refill:P1+Qwh1	
	2	Cold wash	1'				
	3	Heating	T				
	4	Maintenance	14'				
	5	Drain	VAE+14"	No Mov			
Rinses	1st rinse	6	Water fill	P1	No Mov		
		7	Time water fill	Qwor1 (*)	Pwl_4	Refill:P1	
		8	Movement	3'			
	9	Drain	VAE+14"				
	2nd rinse	10	Water fill	P1	No Mov		
		11	Time water fill	Qwor1 (*)	Pwl_4	Refill:P1	
		12	Movement	3'			
	13	Drain	VAE+14"	No Mov			
	Last rinse (softener)	14	Water fill	P1	No Mov		
		15	Movement	30"	Pwl_4	Refill:P1	
		16	Time water fill	Qwor2 (*)			
		17	Movement	5'			
18		Drain	VAE+14"	No Mov			
19	Drain + spin	3,5'	WOOL_CF		(max. 1000rpm)		

#### Notes:

P1 time needed to 1<sup>st</sup> level water fill

(\*) time water fills are changeable and calculated by the electronic on the basis of the delivery rate (see specific table)

T time needed to heat the water at the set temperature

" seconds

' minutes

VAE time needed to drain the water till "empty" position of anti- boiling (safety heater) pressure switch

#### 4. Control of water level in tub

The water fill is carried out in two phases:

- **level fill:** is controlled by the closure of 1<sup>st</sup> level pressure switch in full position
- **time fill:** the duration is calculated by the electronic to fill the set quantity.

The different levels are determined by the model configuration and depend on the type of tub used.

Type	Description of time fill	G20 litres	G22 litres
<b>Levels for COTTON/LINEN</b>			
<b>Qpw1</b>	First prewash water fill <i>(all cycles)</i>	3.5	3.5
<b>Qpw2</b>	Prewash water fill after cold wash <i>(all cycles)</i>	3.5	3.5
<b>Qh1</b>	Normal water fill/half load	3.5	3.5
<b>Qh12</b>	Half load water fill for "VERY SHORT" cycle	4.5	4.5
<b>Qe</b>	Water fill for "energy label" cycle	4.5	3.5
<b>Qec</b>	Water fill for maintenance cold wash "energy label" cycle	0	0
<b>Qwe</b>	Refill for "energy label" cycle if prewash has not been selected	0	0
<b>Qw</b>	Wash refill if the cycle is not "energy label"	1.5	1.5
<b>Qc</b>	Cooling water fill	3.0	3.0
<b>Qs</b>	"Stains" compartment water fill	1.5	1.5
<b>Qk</b>	Water fill for "quick cycle" rinses	12.5	12.5
<b>Qn1</b>	Normal water fill for 1 <sup>st</sup> rinse	7.5	8.5
<b>Qn2</b>	Normal water fill for other rinses	9.0	9.5
<b>Qn3</b>	Normal water fill for last rinse	10.0	12.5
<b>Qn3e</b>	Water fill for economy last rinse	10.0	12.5
<b>Qne</b>	Normal water fill for rinse of "energy label" cycle	4.0	4.0
<b>Qne_60</b>	Water fill for rinse of "energy label" cycle	4.0	4.0
<b>Qsr1</b>	Water fill for super-rinse and night cycle if no spin has occurred	5.5	5.5
<b>Qsr2</b>	Water fill for super-rinse and night cycle if spin has occurred	6.0	6.0
<b>Levels for SYNTHETICS</b>			
<b>Qsy</b>	Wash water fill	1.0	1.0
<b>Qsy1</b>	Wash water fill for VERY SHORT cycle	3.5	4.0
<b>Qy1</b>	Wash water fill if prewash has not been selected	2.0	2.0
<b>Qyr1</b>	Normal water fill for 1 <sup>st</sup> rinse	8.0	8.5
<b>Qyr2</b>	Normal water fill for other rinses	8.0	8.5
<b>Qyr3</b>	Normal water fill for last rinse	9.5	10.0
<b>Levels for DELICATES</b>			
<b>Qdw1</b>	Wash water fill	8.5	9.0
<b>Qdw2</b>	Wash refill	0	0
<b>Qrd1</b>	Normal water fill for 1 <sup>st</sup> rinse and other rinses	10.0	11.0
<b>Qrd2</b>	Normal water fill for last rinse	11.0	11.5
<b>Levels for WOOL</b>			
<b>Qwo</b>	Wash water fill	10.0	10.5
<b>Qwo1</b>	Wash refill	0	0
<b>Qwor1</b>	Normal water fill for 1 <sup>st</sup> rinse and other rinses	8.0	8.5
<b>Qwor2</b>	Normal water fill for last rinse	8.0	8.5
<b>Levels for HAND WASH</b>			
<b>Qwh</b>	Wash water fill	10.0	10.5
<b>Qwh1</b>	Wash refill	0	0

#### 4.1 Profile of cottons/linen 60°C eco / energy label cycle

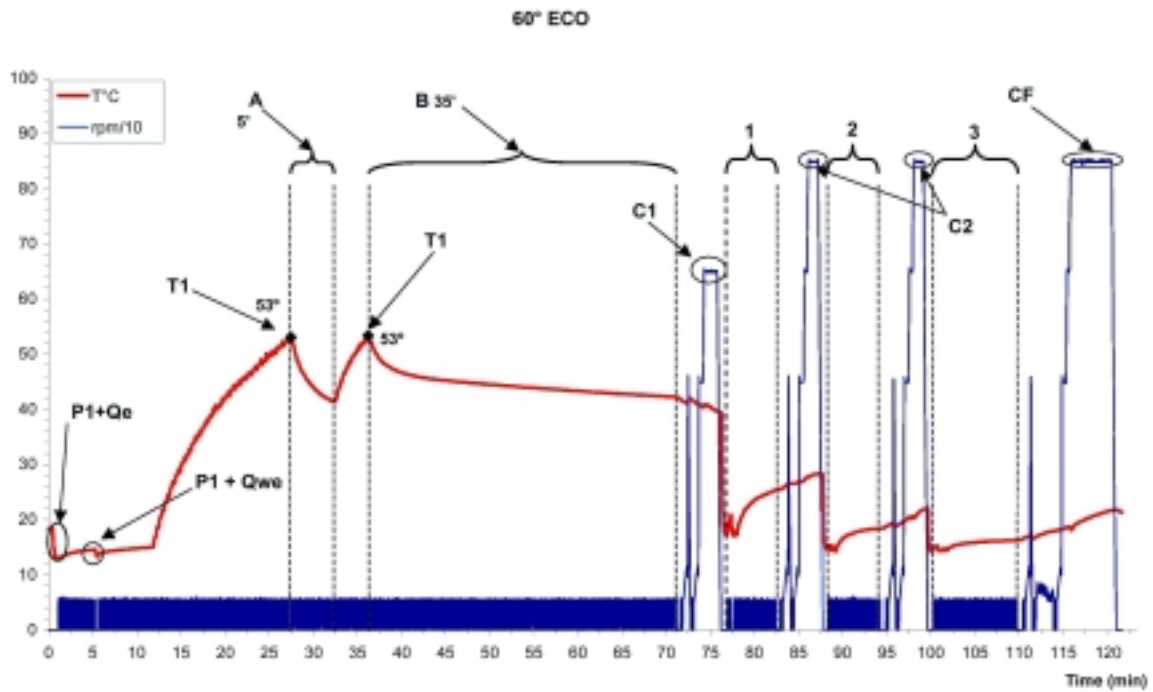

P1+Qe	1 <sup>st</sup> water fill	1	1 <sup>st</sup> rinse
P1+ Qwe	Refill water	2	2 <sup>nd</sup> rinse
A	Movement for 5 minutes	3	3 <sup>rd</sup> rinse
B	Movement for 35 minutes	C1	C1 wash spin
T1	Heating till 53°C	C2	C2 intermediate spin
		CF	CF final spin

#### 4.2 Profiles of cottons/linen 60°C cycles

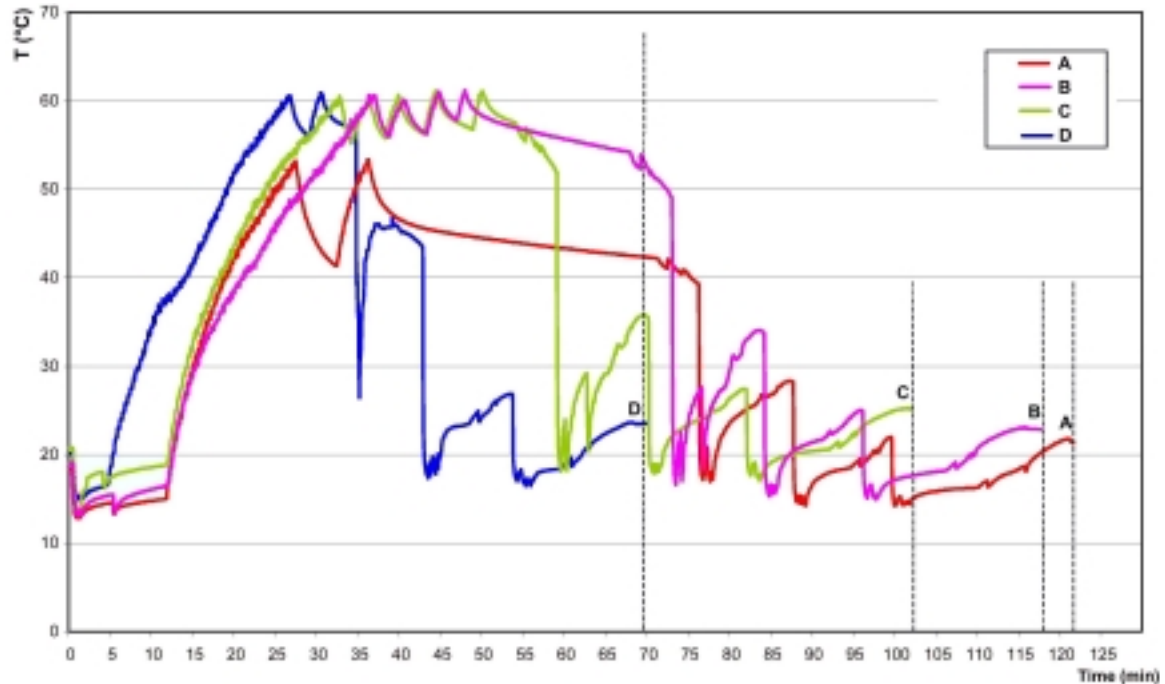

	Cycle	Water consumption (litres)	Time (min)
A	Economy or "energy label"	52	125
B	Normal (consumer)	56	120
C	Quick	56	100
D	Very short	49	70

*Note:* The data are indicative, for the correct values please refer to those of the specific models.

### 4.3 Profile of cottons/linen 95°C

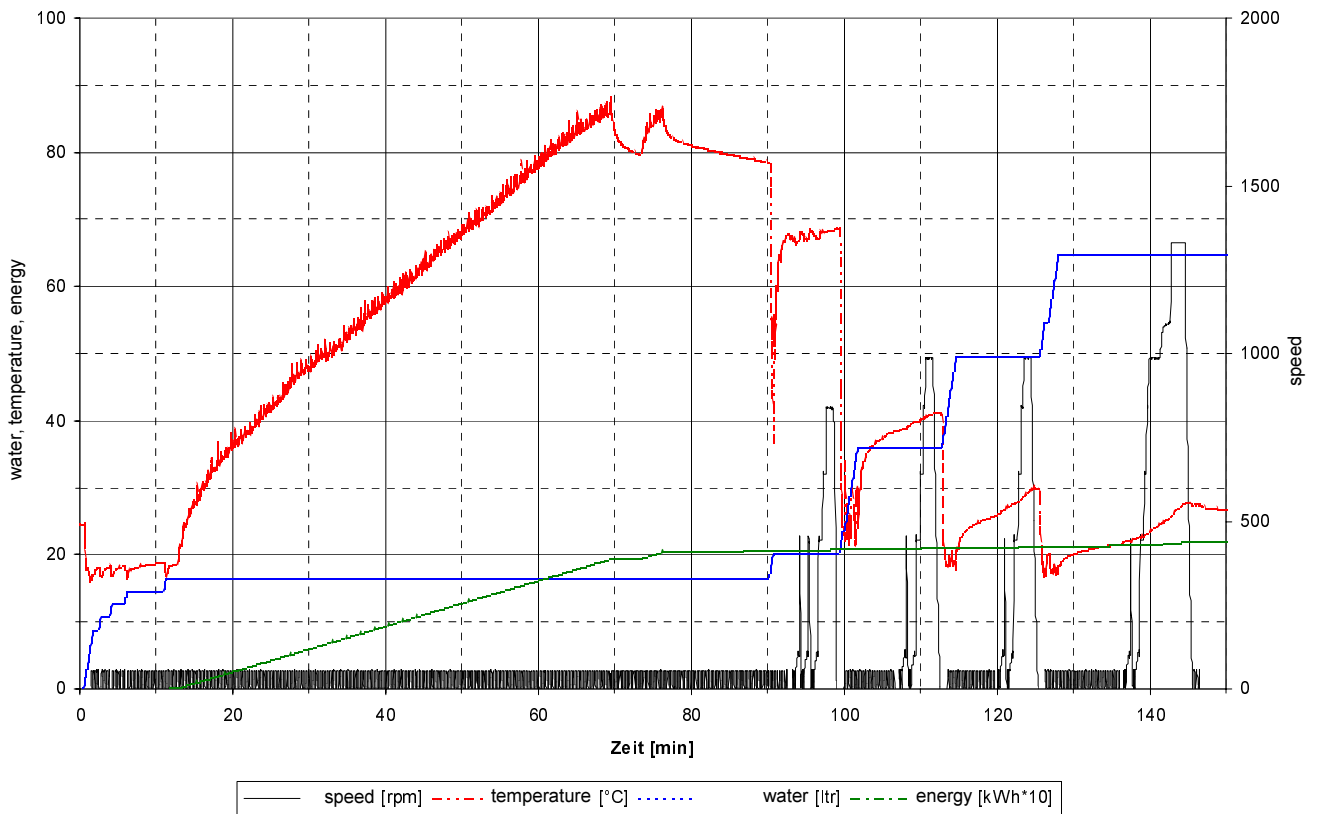

### 4.4 Profile of cottons/linen 40°C

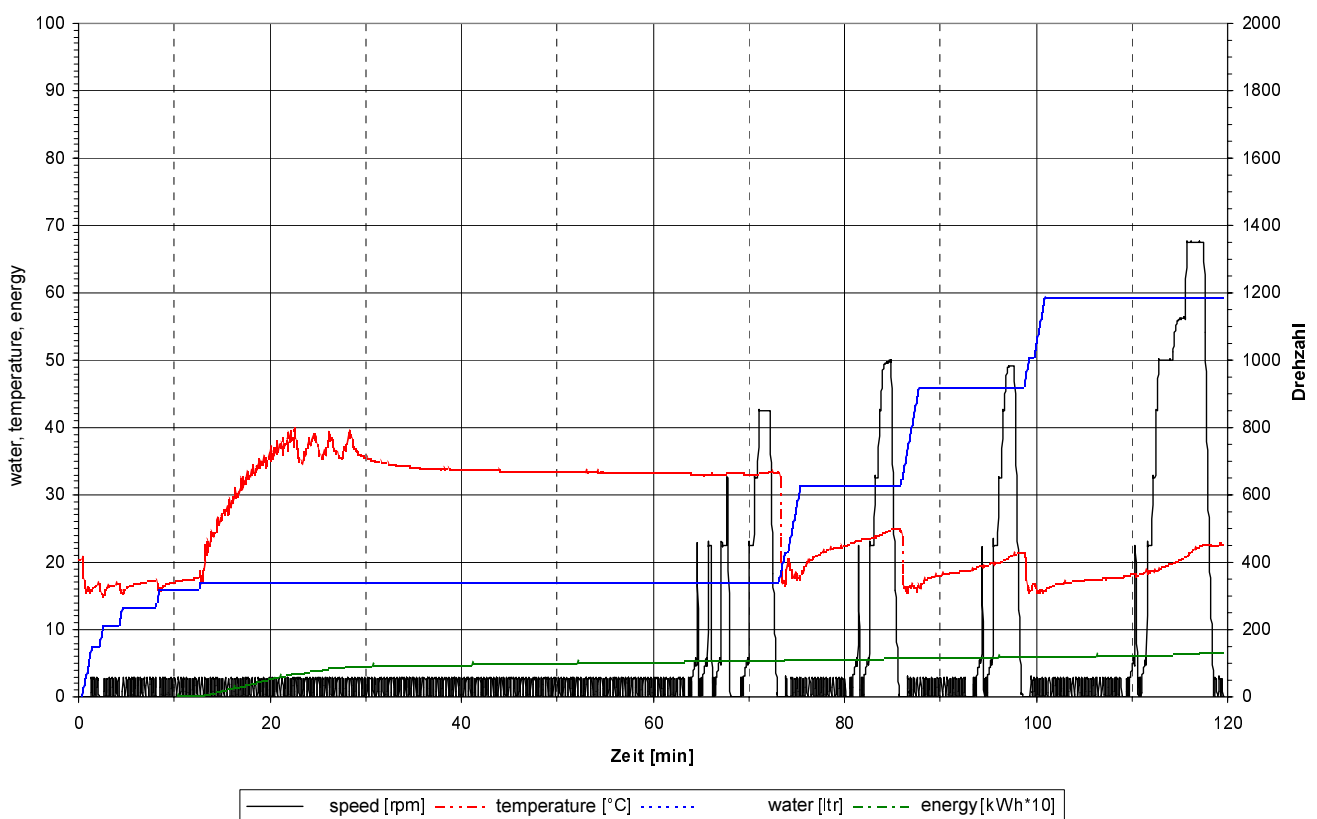



#### 4.5 Profile of delicates 30°C

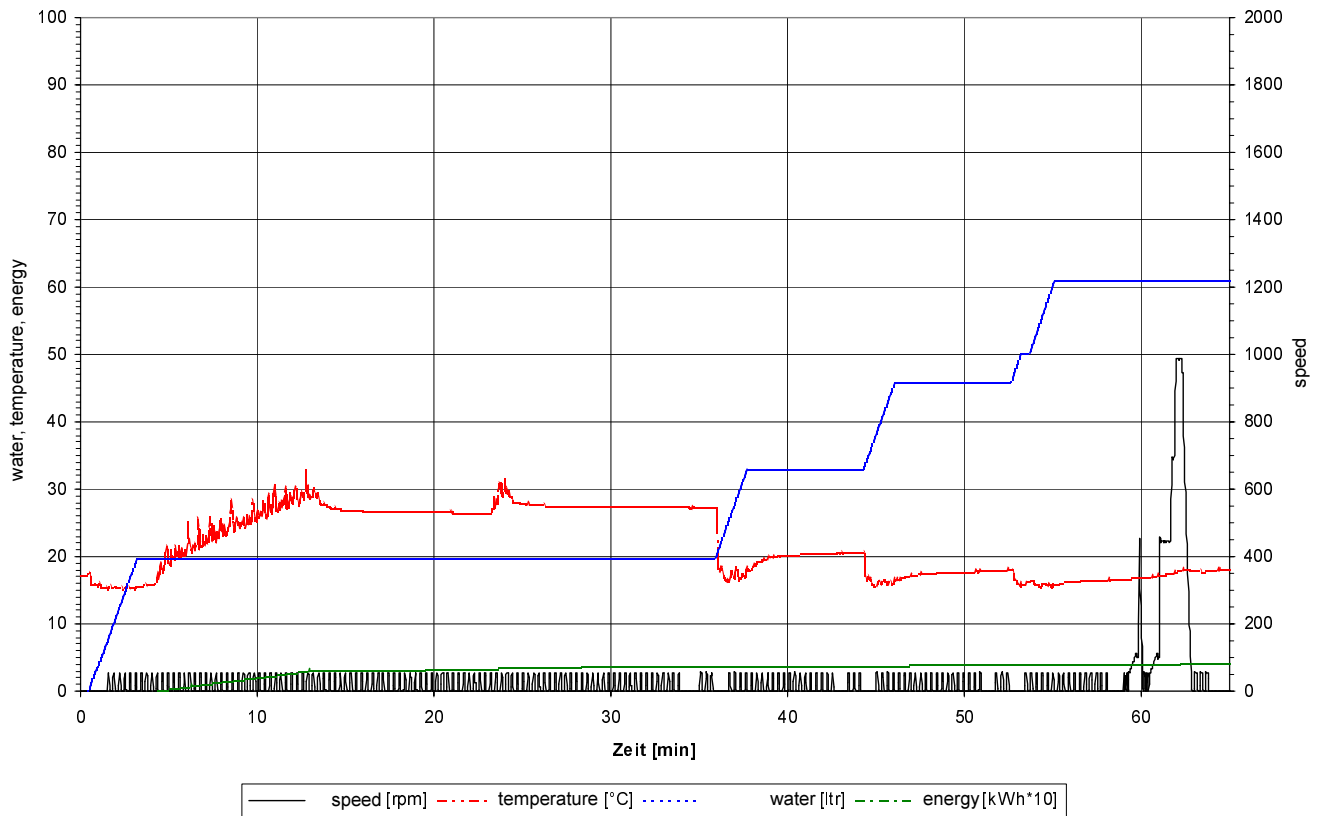

#### 4.6 Profile of wool 40°C

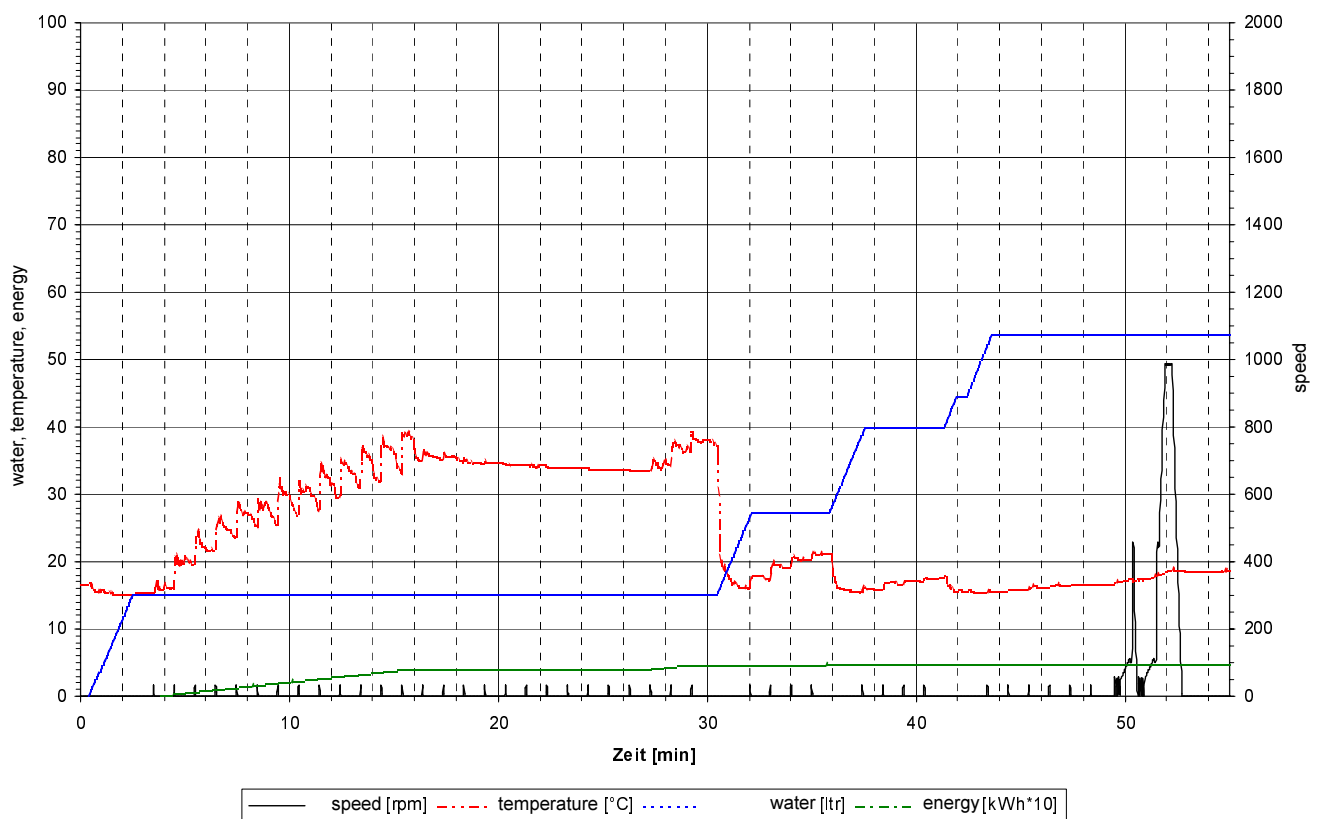

5. Drum movements

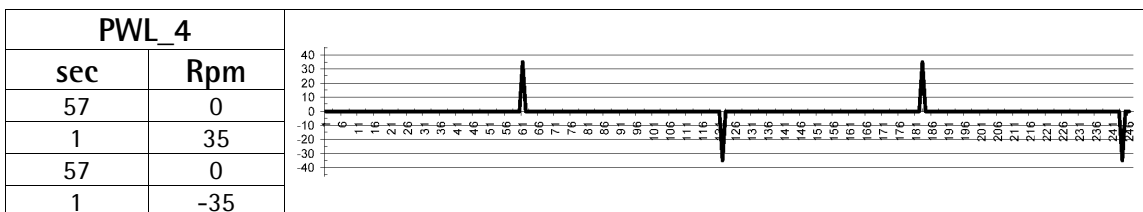
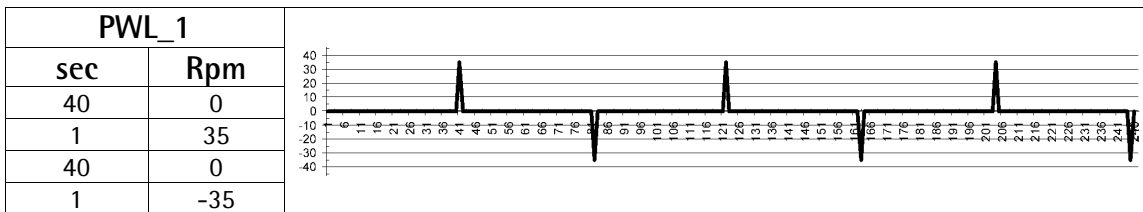
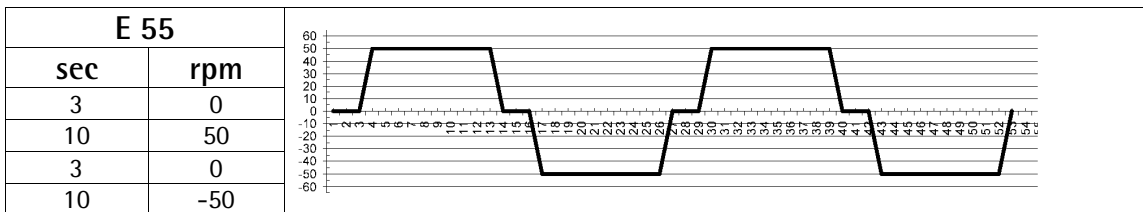
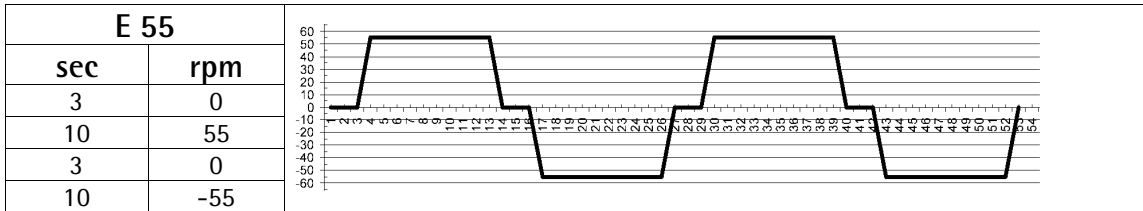
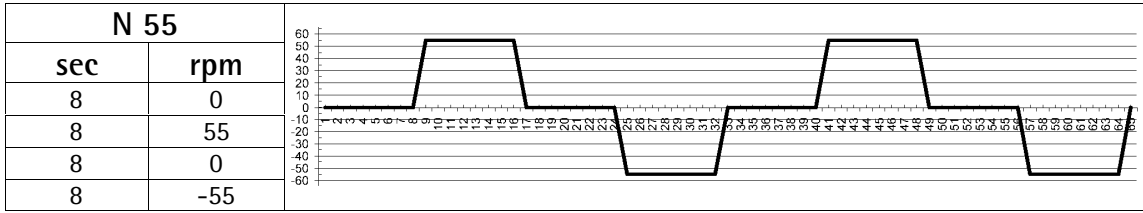
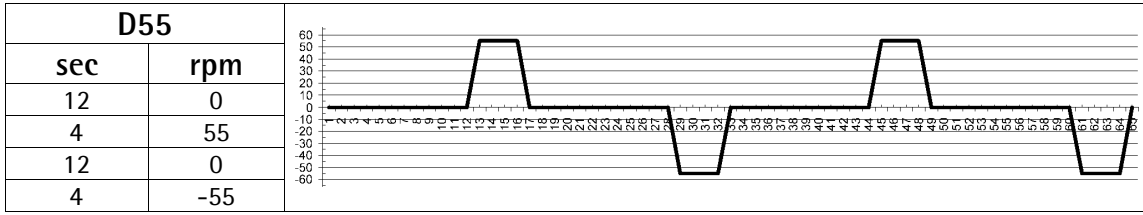

## 6. Spinning profiles

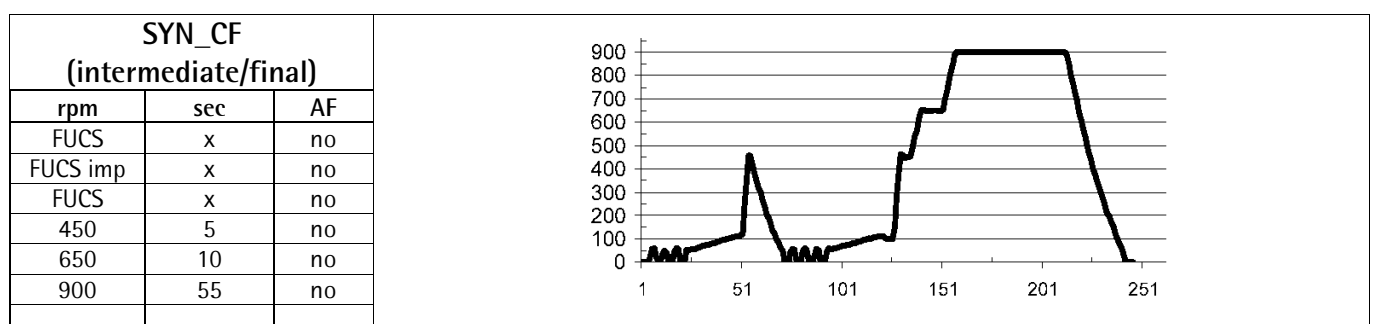
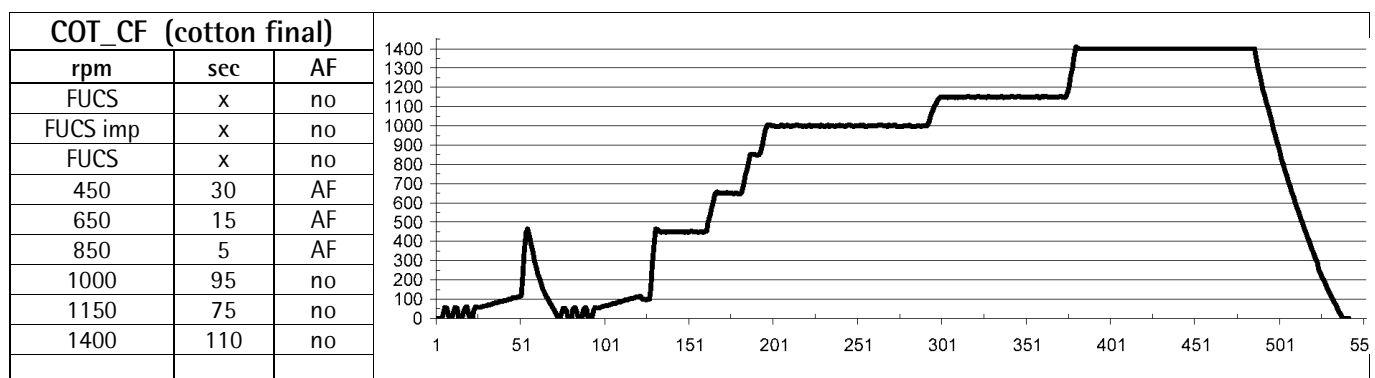
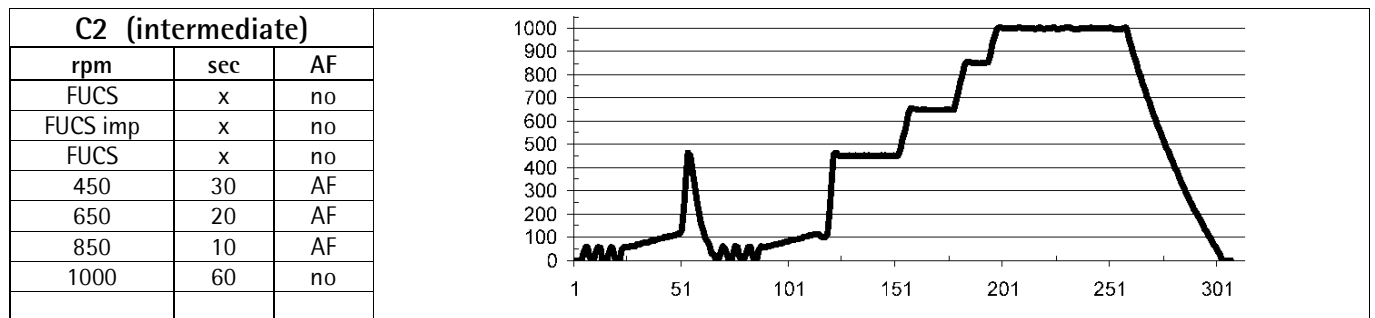
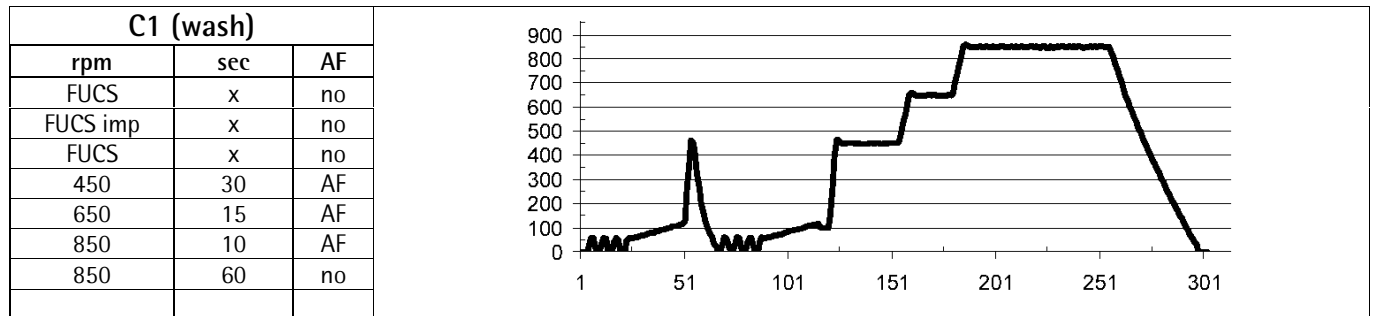
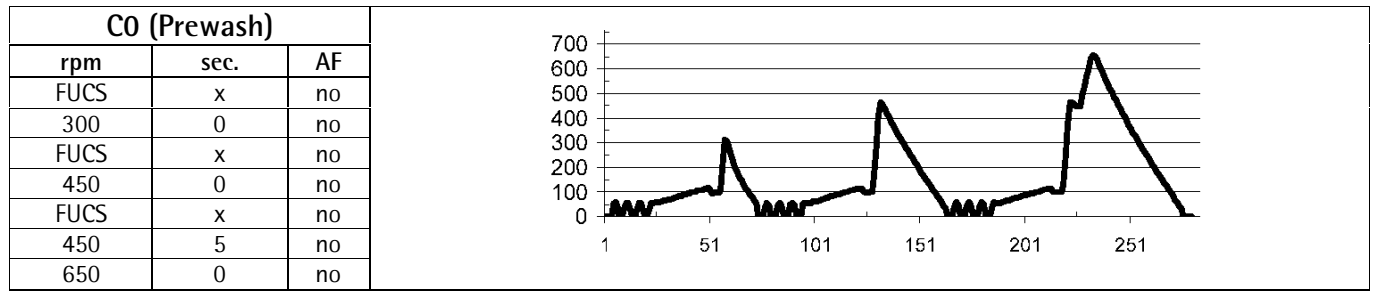

CF (delicates final)		
Rpm	sec	AF
FUCS	x	no
FUCS imp	x	no
FUCS	x	no
450	35	AF
700	5	AF
900	20	AF

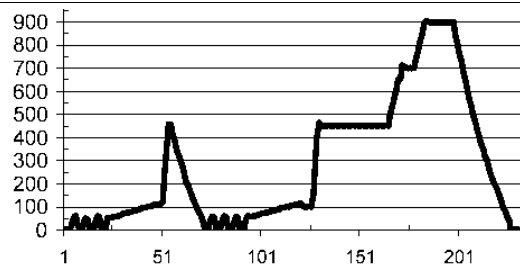

CF (wool final)		
rpm	sec	AF
FUCS	x	no
FUCS imp	x	no
FUCS	x	no
450	5	AF
650	1	AF
850	1	AF
1000	20	no

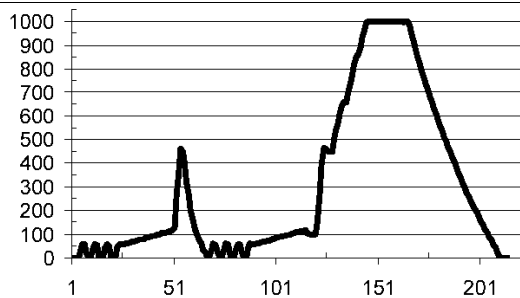

Spin Cycle		
rpm	sec	AF
FUCS	x	no
FUCS imp	x	no
FUCS	x	no
450	10	AF
650	10	AF
850	10	AF
1000	10	no
1150	10	no
1400	20	no

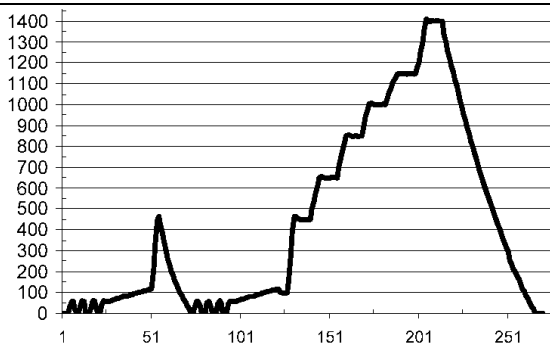

EASY_IRON_IMP		
rpm	sec	AF
FUCS	x	no
450	0	no
FUCS	x	no
650	0	AF
FUCS	x	no
800	0	AF
FUCS	x	no
900	0	AF

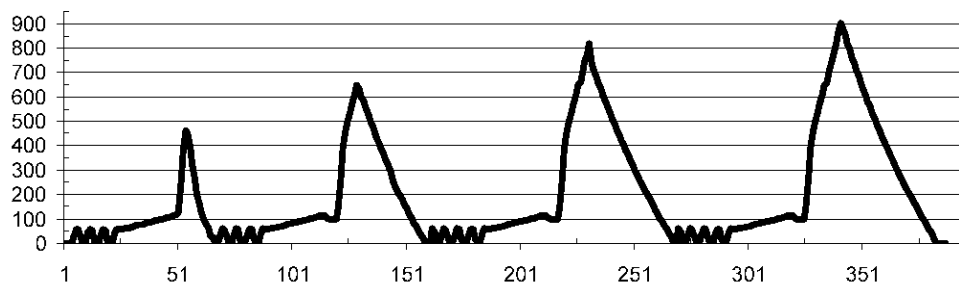

CSR		
rpm	sec	AF
FUCS	x	no
FUCS imp	x	no
FUCS	x	no
450	120	AF

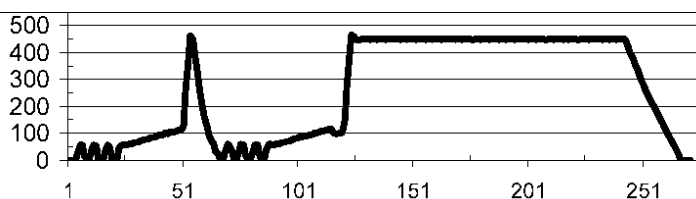

## 7. Technical characteristics

### 7.1 EWM1000 plus electronic control

#### 7.1.1 Functions of the circuit board

The EWM1000 plus electronic control consists of a main PCB and a control/display board.

The circuit board receives signals relative to the cycle settings via the control/display board. The buttons, the LEDs and the display are also mounted on this board which is connected to the programme selector.

The board also powers all the electrical components (solenoid valves, washing motor, drain pump, heating element, door interlock).

The board controls the temperature of the washing water via an NTC sensor, as well as the speed of rotation of the washing pump according to the signal received from the tachymetric generator. It checks the water level in tub via the level pressure switch and the safety one.

As spare part there is a configured main PCB available. The spare part number is listed in the spare part list.

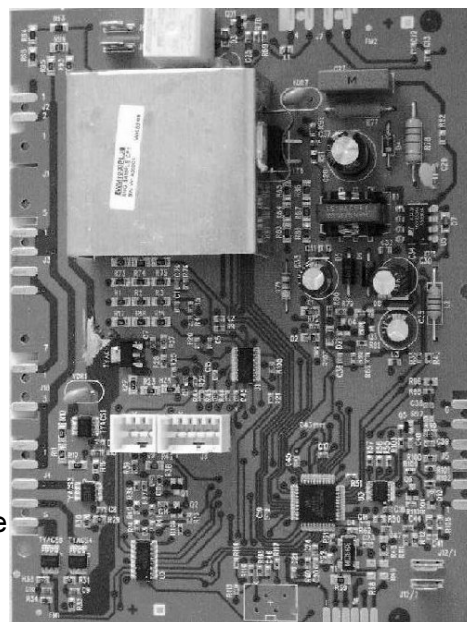

#### 7.1.2 Contacts of the circuit board

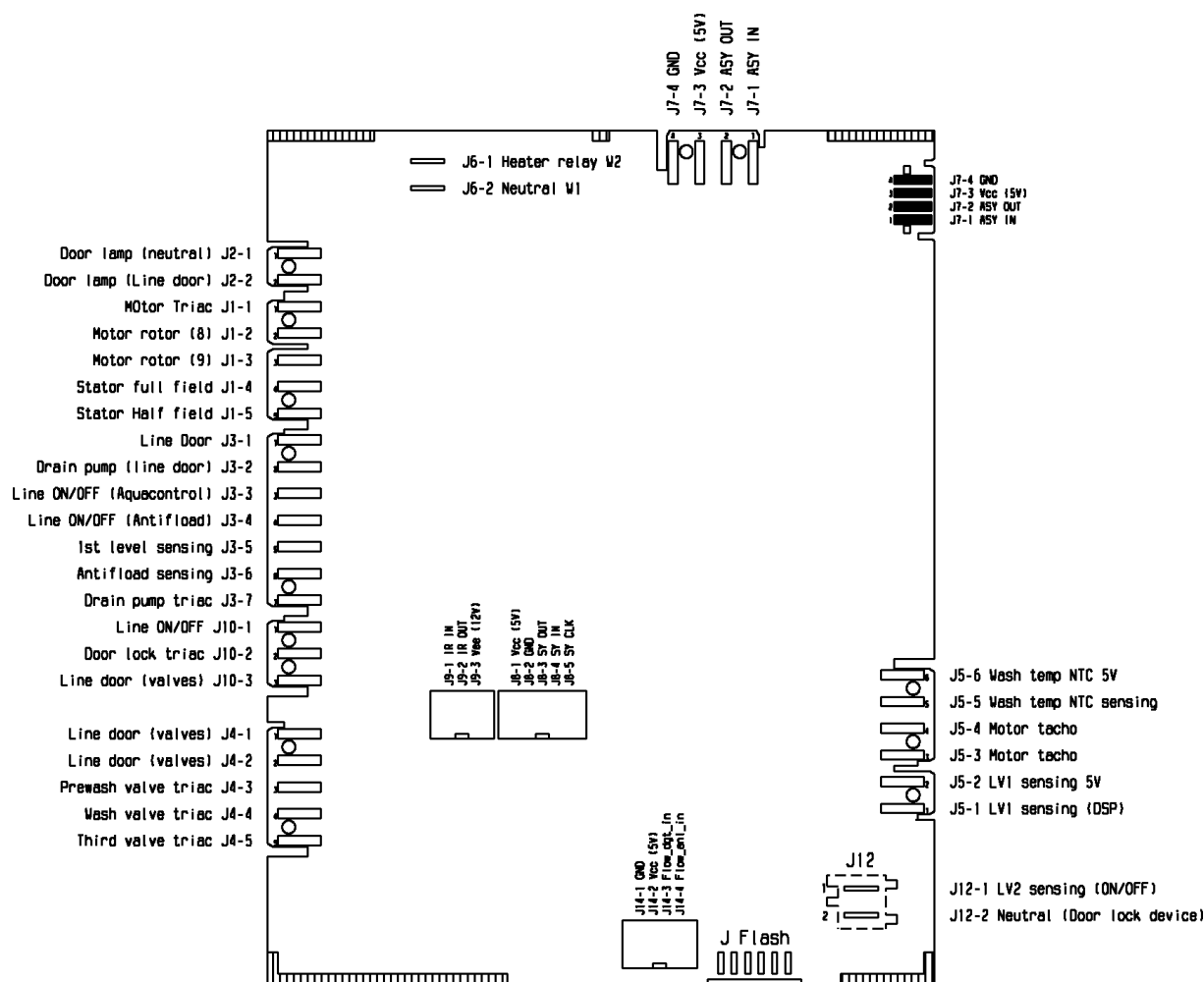

## 7.2. Programme-selector

21- position programme-selector with integrated main-switch. To check the programme selection-switch, measure the resistance between the common contact C6 and the several contacts C1-C5, which should be closed according this tables.

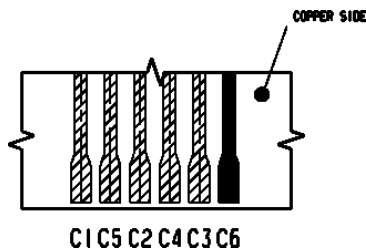
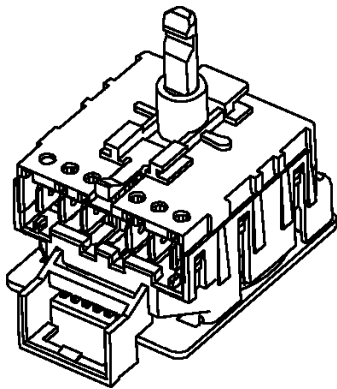

°	Pos.	C6				
		C5	C4	C3	C2	C1
0°	1	X	X	X	X	
32°	2	X			X	
47.58°	3			X	X	
63.16°	4		X		X	
78.74°	5		X	X	X	
94.32°	6	X	X			
109.90°	7					X
125.48°	8		X			X
141.06°	9	X	X		X	
156.64°	10	X		X		
172.22°	11	X	X			X
187.80°	12		X	X		
203.38°	13	X		X		X
218.96°	14		X	X		X
234.54°	15	X	X	X		X
250.12°	16				X	X
265.70°	17	X		X	X	
281.28°	18	X				
296.86°	19					X
312.44°	20		X			
328°	21			X		

**7.3 The doorlock**  
**7.3.1 Thermal doorlock**

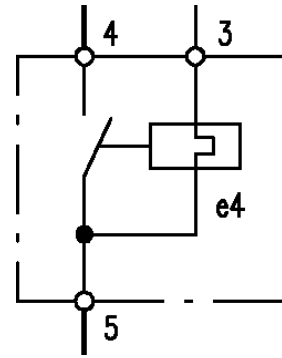
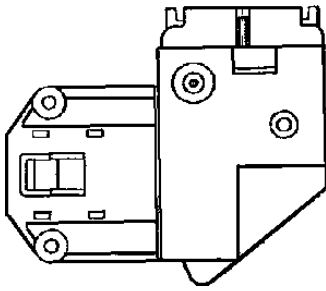

**Doorlock function:**

When the washing programme is started by pressing the START/ PAUSE button, the bi-metal PTC (contacts 3-5) is powered by the triac on the PCB: after 2-4 seconds, this closes the switch (5-4) which powers the electrical components of the appliance (only if the door is closed).

The door interlock prevents aperture of the door while the appliance is in operation.

At the end of the washing programme, the PCB disconnects the interlock from the power supply, but the door remains locked for 1 to 2 minutes (PTC cooling time).

**7.3.2 Instantaneous doorlock (IDOLO)**

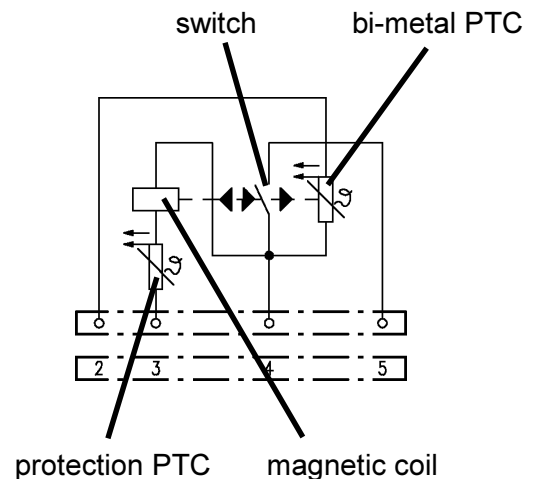
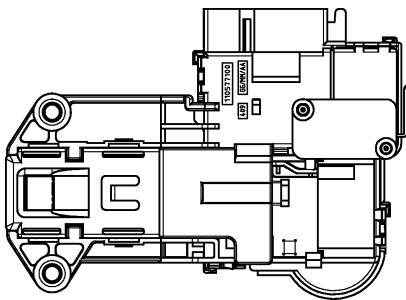

**Doorlock function:**

Door locking is controlled directly from the control electronic. For enabling the lock, one impulse is necessary, for disabling the lock, two impulses. You can recognize these control impulses at the door lock as a simple or double clicking sound.

**Prerequisites for door opening:**

- Drum is at standstill (no signal from tachometer generator)
- No water may be present above the lower door rim (level <fN2)
- Water temperature may not exceed 40°C.

**Automatic unlocking device:**

- if the appliance is switched off or disconnected from the mains, the PTC bimetal will cool down, and after about 1-4 minutes, the locking mechanism will be disabled.

**Safety function:**

A PTC is switched in series to the magnetic coil to limit power and therefore avoid possible overheating due to the following causes:

- TRIAC is short-circuited on the control electronics
- Repeated activation of the Start/Pause key (more than 10 times)

## 7.4 Pressure switch

Control of the water level is performed by a three-level pressure switch which functions as follows:

- contact 11-14: anti-boiling safety level
- contact 21-24: first level
- contact 31-32: anti-flooding safety level

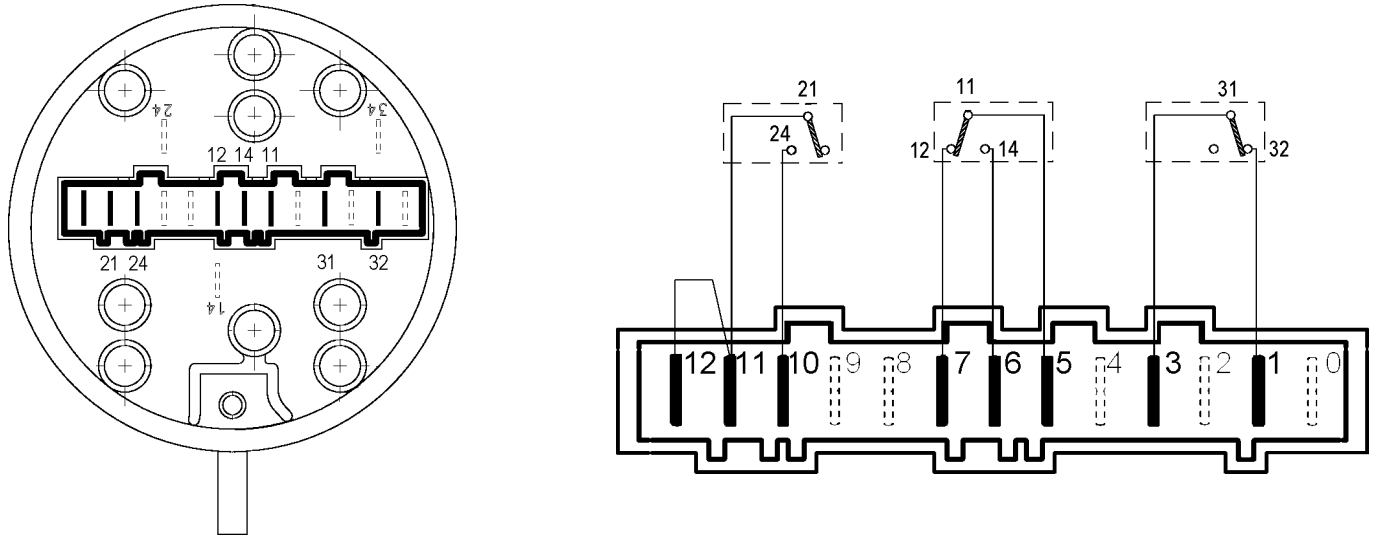

	Full (mm)	Reset (mm)
Anti-boiling level	$55 \pm 3$	$35 \pm 3$
1st level	$80 \pm 3$	$55 \pm 3$
Anti-flooding level	$390 \pm 15$	$240 \pm 50$



## 7.5 Water fill system

The solenoid valves are powered by the PCB via two triacs. The status of the pressure switch (empty/full) is detected by two "sensing" lines.

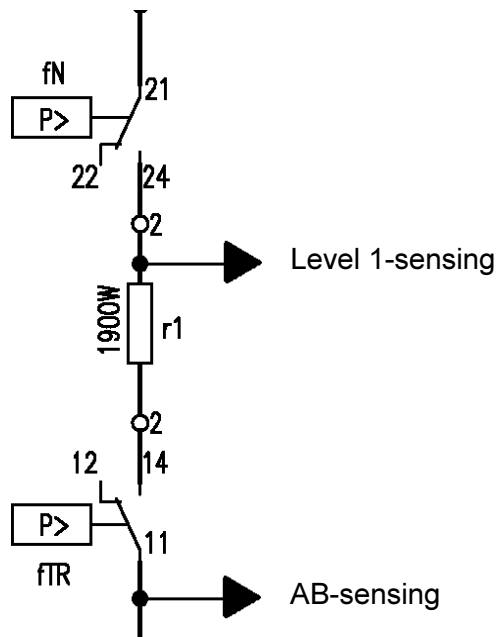

Phase A: The phase during which the initial fill takes place:

1. Water fill until the anti-boiling pressure switch closes on FULL.
2. Water fill until the 1st level pressure switch closes on FULL: the delivery of the solenoid is calculated during this phase.
3. Water fill for time Q, which varies according to delivery and cycle phase.

Phase B:

If the 1st level pressure switch returns to EMPTY, a supplementary fill is performed until the pressure switch returns to close on FULL. This phase may be followed by a further timer-controlled fill.

## 7.6 Anti-flooding-device

The third pressure switch level is used as an anti-flooding safety device: if the pressure switch contact should close in the FULL position, the PCB actions the drain pump until the pressure switch returns to the EMPTY position.

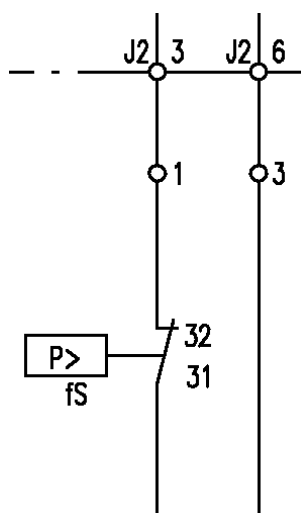

## 7.7 Heating element



Connection: 230V; 50Hz;  
 Power: 1950W  
 Fuse: 10A

The heating element is powered by a relay on the PCB via the contacts of the pressure switch when closed on FULL.

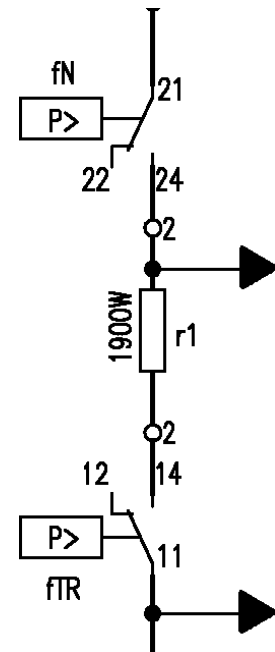

## 7.8 NTC-sensor

The temperature is controlled by the PCB by means of a NTC temperature sensor.

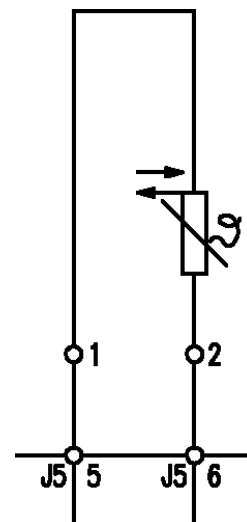
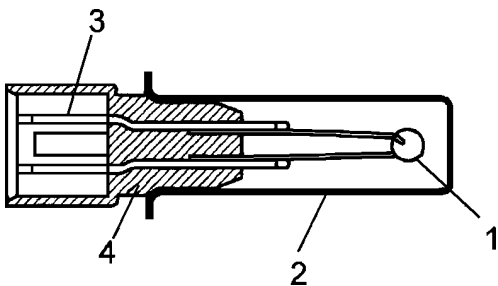

To check the NTC sensor function you can measure the ohmic resistance between the contacts J5/1 and J5/2.

Temperature (°C)	resistance (Ω)
20	6050
60	1250
80	640

## 7.9 Drain pump

The PCB powers the drain pump via a triac as follows:

- for a pre-determined period
- until the anti-boiling pressure switch closes on EMPTY, after which the pump is actioned for a brief period or passes to the subsequent phase.

## 7.10 Motor

The PCB powers the motor via a triac. The direction of rotation is reversed by switching of the contacts on the two relays (K2-K3), which modify the connection between the rotor and the stator. In certain models, a third relay (K4) is used to power the stator (full or half range) according to the spin speed.

The speed of rotation of the motor is determined by the signal received from the tachymetric generator (g1).

During the spin phases, the microprocessor, depending on the software configuration, may perform the anti-foam control procedure and the anti-unbalancing control procedure.

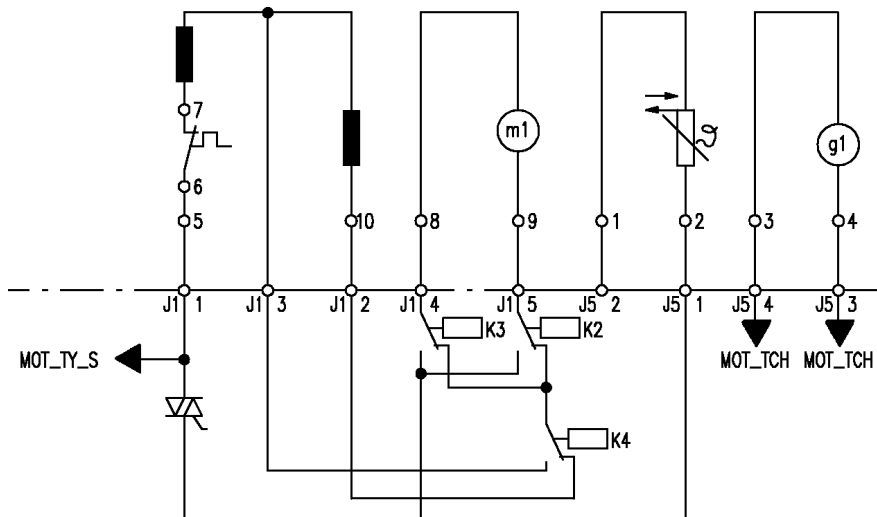

Connection:

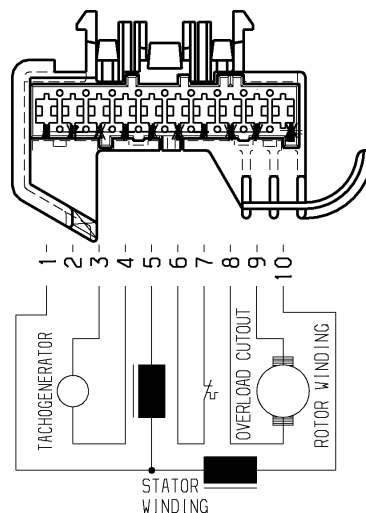

Article number	Connection	Tacho (3-4)	Rotor (8-9)	Stator (5-1)	Stator complete (5-10)
124 306 103 FHP	230V; 50Hz AC	135Ω +/-8%	1,95Ω +/-8%		1,70Ω +/-8%
124 309 903 FHP	230V; 50Hz AC	135Ω +/-8%	1,75Ω +/-8%		1,12Ω +/-8%
132 079 901 FHP	230V; 50Hz AC	135Ω +/-8%	1,71Ω +/-8%	0,49Ω +/-8%	1,26Ω +/-8%

## 7.11 Anti-foam control system

The anti-foam control procedure is performed via the anti-boiling pressure switch (AB).

Spin phase without foam

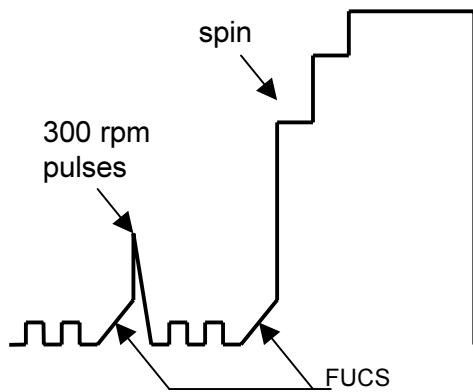

Spin phase with little foam

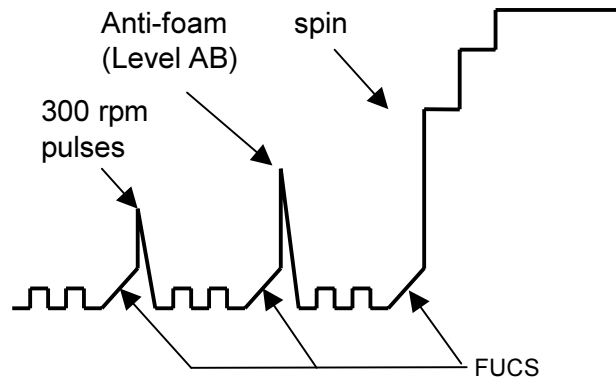

- Spin with little foam: if the contact of pressure switch AB closes on FULL, the spin phase is interrupted; the drain pump continues to operate and, when the contact returns to EMPTY, the spin phase is resumed.
- Spin with excessive foam in the tub (critical situation): The control system detects whether the pressure switch commutates 5 times to FULL. in this case, the spin phase is skipped, and a one-minute drain cycle is performed with the motor switched off; in the case of a washing phase, a supplementary rinse is added.

## 8. Fast Unbalance Control System (FUCS)

The control procedure for unbalanced loads is performed dynamically, before each spin cycle, as follows:

- An initial phase is performed in which the direction of rotation of the drum is alternated at 55 rpm.
- The phase begins at a speed of 55 rpm; the speed can never fall below this threshold, otherwise the check is repeated.
- At intervals of 300 ms, the balance is calculated and compared with predetermined limits. If the value is less than the lower limit, the speed of the drum is increased by 2 rpm; if the value is higher, the speed of the drum is reduced by 2 rpm. The reduction in the speed of the drum distributes the washing correctly; this procedure is repeated until the wash load is completely balanced.
- Correct balancing of the wash load is achieved at a speed of 115 rpm, after which the spin cycle begins.

The unbalancing control function takes place in four phases; each phase is characterized by an unbalancing threshold and a time-out (maximum time).

**Phase 0:** Phase 0 has a pre-determined unbalancing threshold; if correct balancing of the wash load is achieved, the appliance performs a 470 rpm spin pulse, preceded by 5 seconds at 100 rpm and followed by phase 1; otherwise, after a maximum of 60 seconds, the cycle passes directly to phase 1.

**Phase 1:** The first phase has a different preset unbalancing threshold: if correct balancing is achieved, the appliance performs the spin cycle, preceded by 5 seconds at 100 rpm. If not, after a maximum of 120 seconds, the cycle passes to phase 2.

**Phase 2:** The pre-determined unbalancing threshold in the second phase is different: if correct balancing is not achieved within 60 seconds, the function passes to phase 3.

**Phase 3:** The third phase has a pre-determined unbalancing threshold: if correct balancing is achieved within 90 seconds, a spin pulse is performed, preceded by 5 seconds at 100 rpm and followed by a repeat of phase 1. If the load is highly unbalanced after the second attempt for phase 3, the spin cycle is skipped; if balancing is not perfect, a reduced-speed spin is performed.

### 8.1. Examples of operation of the unbalancing control function

The examples shown below describe the operation of an appliance with a final spin speed of 1000 rpm.

Perfect balancing

- Low speed
- FUCS phase 0 with spin pulse
- Low speed
- FUCS phase 1
- Normal spin

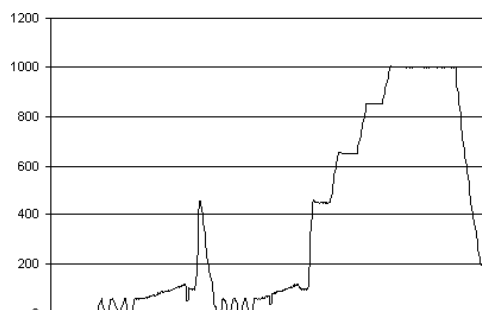

### Balancing after two attempts

- Low speed
- FUCS phase 0
- FUCS phase 1
- FUCS phase 2

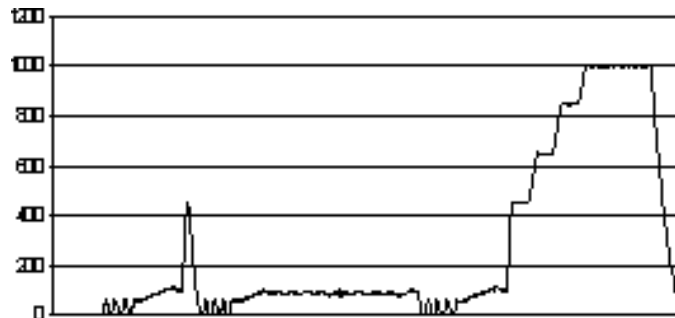

### Balancing after the third phase (normal spin-speed)

- FUCS phase 0 with spin pulse
- FUCS phase 1
- FUCS phase 2
- FUCS phase 3 with spin pulse
- FUCS phase 1
- FUCS phase 2
- FUCS phase 3
- Normal spin

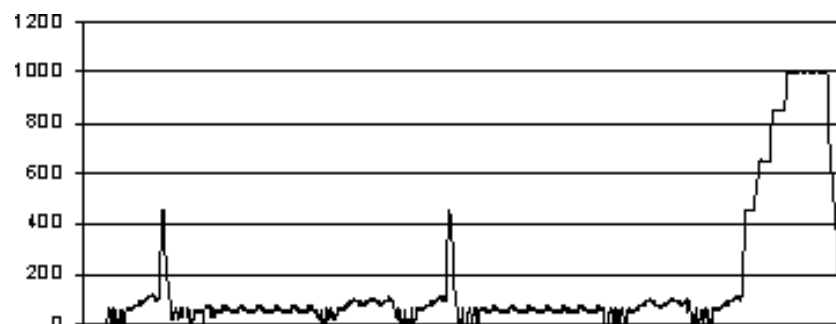

### Balancing after the third phase (reduced spin-speed)

- FUCS phase 0
- FUCS phase 1
- FUCS phase 2
- FUCS phase 3 with spin pulse
- FUCS phase 1
- FUCS phase 2
- FUCS phase 3
- reduced-speed spin

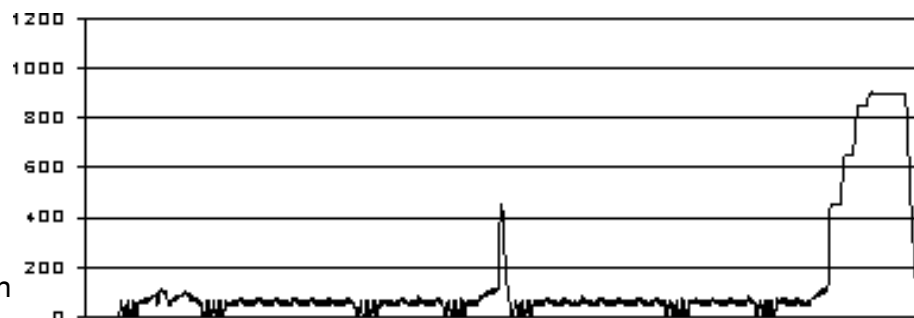

### Unalancing after the third phase

- FUCS phase 0
- FUCS phase 1
- FUCS phase 2
- FUCS phase 3
- FUCS phase 1
- FUCS phase 2
- FUCS phase 3
- no spin

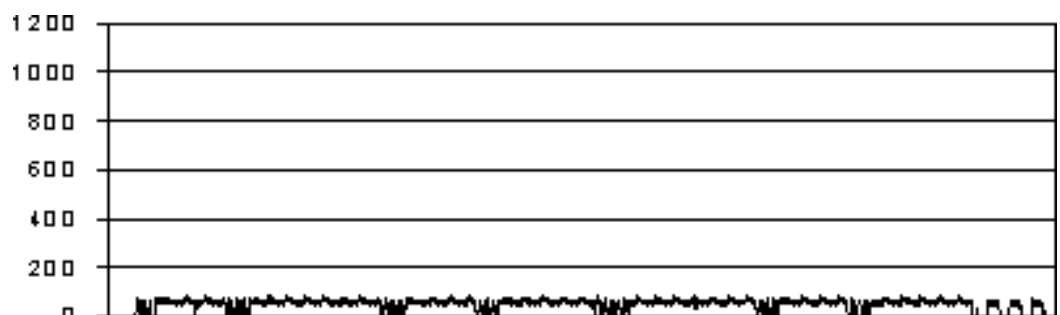

## 9. Service test programme

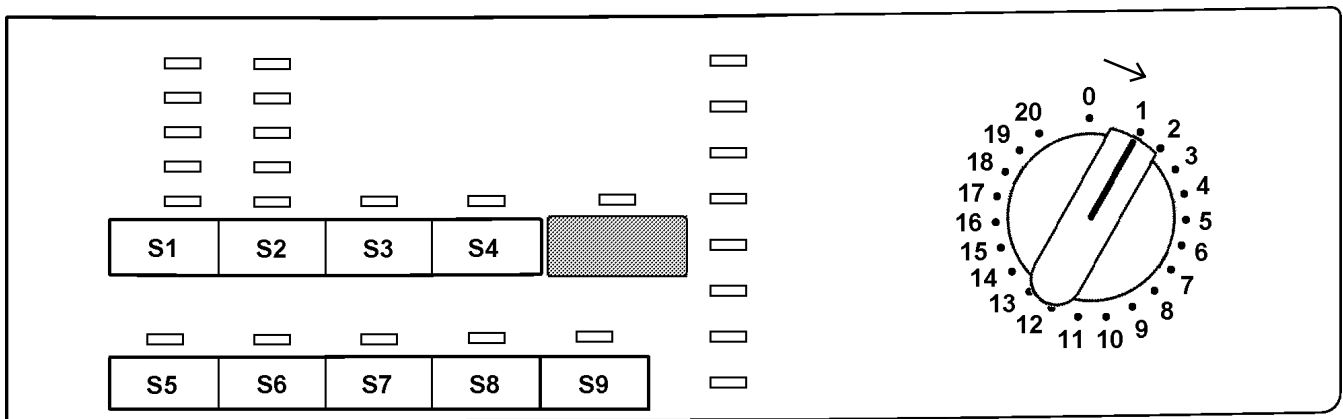

### 9.1 Access to service test programme:

Due to various panel configurations the button combinations to activate the service programme can be different. In each case **the first two buttons seen from left (S1 and S5 or S2 and S6)** are defined for activation of the service programme.

- Switch off the appliance (programme selector position 0).
- Press and hold down **button S1 and S5** or **button S2 and S6** simultaneously.
- Holding down both buttons, switch the appliance on by turning the programme selector **one position to the right** (clockwise).
- Continue to hold down both buttons at least 2 sec. until the LEDs begin to flash.

Irrespective of the type of PCB and the configuration of the programme selector it is possible, after entering service test mode, to perform diagnostics on the operation of the various components and to read the alarms by turning the programme selector clockwise.

All the alarms are enabled during the diagnostics cycle.

Position 1:	LED-test
Position 2:	Water ducted through washing compartment (water level below fS, max. 5 min.)
Position 3:	Water ducted through pre-wash compartment (water level below fS, max. 5 min.)
Position 4:	Water ducted through conditioner compartment (water level below fS, max. 5 min.)
Position 5:	Water ducted through stain compartment, optional (water level below fS, max. 5 min.)
Position 6:	Heating (water level above 1st level, max. 10 min. or up to 90°C)
Position 7:	Check for leaks from the tub (water level above 1st level, motor 55 rpm, 250rpm impulse)
Position 8:	Drain and spin (drain pump, motor up to 650 rpm then at max. spin speed)
Position 9:	Not used
Position 10:	Reading the last alarm code. The stored alarm code can be cancelled by pressing buttons <b><u>S1 and S5</u></b> or <b><u>S2 and S6</u></b> .

### 9.2 Exiting service test programme

- To exit the service test programme, switch off the appliance.

**Attention:** According to the machine configuration it is possible that the electric test cycle will be activated with the next switch on of the machine. In the display will appear „ELE“.

To stop it, switch off/on the appliance again.

## **10 Alarms**

### **10.1 User alarm display**

Control of the alarm system can be configured; according to the model, therefore, some or all of the alarms may be displayed to the user.

Normally, all alarms are displayed for the user, with the exception of:

- .. E61 (insufficient heating during the washing phase)
- .. E83 (error in selector reading)

The alarms are enabled during the execution of the washing programme, with the exception of alarms associated with configuration and the power supply (voltage/frequency), which are also displayed during the programme selection phase.

The door can normally be opened (except where specified) when an alarm condition has occurred on condition that:

- the level of the water in the tub is below 1st level
- the temperature of the water is lower than 40°C.

Certain alarm conditions require that a drain phase be performed before the door can be opened:

- Cooling water fill if the temperature is in excess of 60°C.
- Drain until closure of both pressure switch contacts (1st level and anti-boiling safety system) on EMPTY within a maximum of 5 minutes.

#### **10.1.1 Alarms displayed during normal operation**

The type of alarm condition is displayed to the user by the repeated flashing of the END OF CYCLE LED and in the display (if featured). This LED is featured on all models, though configured in different positions. All the LEDs flash to indicate a configuration error.

If, for example, the user should forget to close the door, the control system will detect alarm E41 about 15 seconds after the start of the cycle; the cycle remains in PAUSE mode and the LED flashes repeatedly in the sequence shown in the table.

The four flashes indicate the first of the two digits of alarm E41 (the alarms for a given function are grouped in "families").

In this case, after closing the door, it is sufficient to press START in order to re-start the programme.



## **10.2 Reading the alarm codes**

In order to read the last alarm code memorized in the EEPROM on the PCB:

- Enter service test programme (see page 29)
- Irrespective of the type of PCB and configuration, turn the programme selector clockwise to the tenth position.

### **10.2.1 Displaying the alarm**

The alarm is displayed by a repeated flashing sequence of the two LEDs and in the display (if featured). The buzzer (if featured) will sound "bips" in synchronization with the flashing of the alarm code family.

- END OF CYCLE-LED indicates the first digit of the alarm code (family).
- START/PAUSE-LED indicates the second digit of the alarm code (number within the family).

These two LEDs are featured on all models, though they are configured differently.

Notes:

- The first letter of the alarm code "E" (Error) is not displayed, since this letter is common to all alarm codes.
- The alarm code "families" are shown in hexadecimal; in other words:  
A is represented by 10 flashes  
B is represented by 11 flashes  
...  
F is represented by 15 flashes
- Configuration errors are shown by the flashing of all the LEDs (user interface not configured).

### **10.2.2 Operation of alarms during diagnostics**

All alarms are enabled during the components diagnostics phase.

### 10.3 Rapid reading of alarm codes

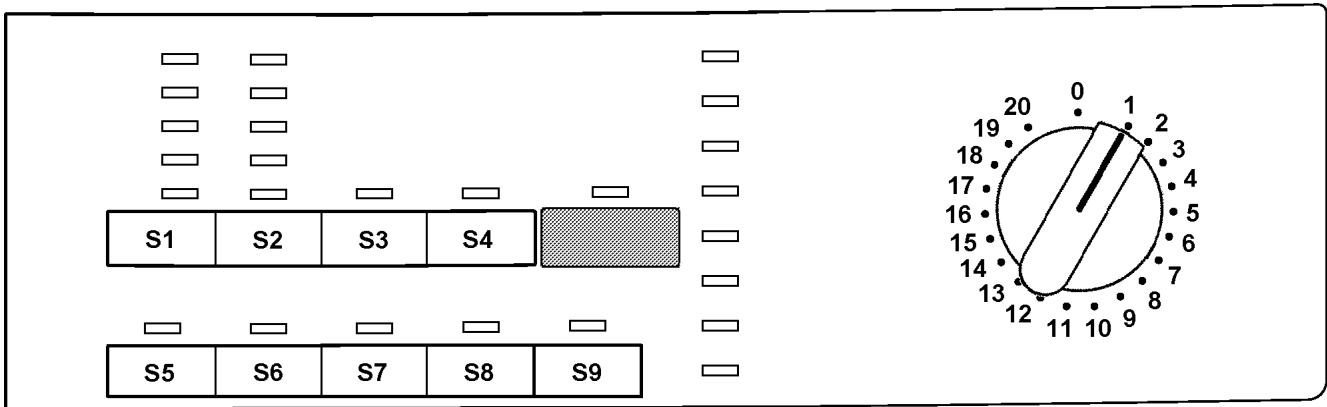

The last alarm code can be displayed even if the programme selector is not in the 10th position (service test mode) or if the appliance is in normal operating mode (e.g. during the execution of an washing programme):

- Press and hold down **button S1 and S5** or **button S2 and S6** simultaneously for at least 2 seconds: the LEDs initially switch off, and then display the flashing sequence corresponding to the alarm.
- The alarm sequence continues as long as the two buttons are held down.
- The alarm reading system is as described in paragraph 10.2
- While the alarms are displayed, the appliance continues to perform the cycle or, if in the programme selection phase, maintains the previously-selected options in memory.

### 10.4 Cancelling the last alarm

- Enter service test programme (see page 29)
- Press and hold down **button S1 and S5** or **button S2 and S6** simultaneously for at least 2 sec.

It is good practice to cancel the last alarm:

- after reading the alarm code, to check whether the alarm re-occurs during diagnostics
- after repairing the appliance, to check whether it re-occurs during testing.

Alarm	Description	Possible fault	Action/machine status	Reset
E11	Difficulties in water fill for washing	Tap closed or mains pressure insufficient; drain hose incorrectly positioned; water fill solenoid faulty; leaks from the hydraulic circuit of the pressure switch; pressure switch faulty; wiring faulty; PCB faulty.	Cycle paused	Start
E13	Water leakage	Drain hose incorrectly positioned; mains pressure insufficient; water fill solenoid faulty; leakage/blockage of pressure switch hydraulic circuit; pressure switch faulty.	Cycle paused	Start
E21	Difficulties in draining	Drain hose kinked/blocked/incorrectly positioned; drain filter blocked/dirty; drain pump faulty; wiring faulty; PCB faulty; current leakage from heating element to ground.	Cycle paused	Start
E23	Drain pump triac faulty	Drain pump faulty; wiring faulty; PCB faulty.	Safety drain cycle – Cycle stopped with door open	Off
E24	Fault in “sensing” circuit of drain pump triac	PCB faulty.	Safety drain cycle – Cycle stopped with door released	Off
E33	Incongruence between closure of anti-boiling and 1st level pressure switch contacts	Pressure switch faulty; current leakage from heating element to ground; heating element; wiring faulty; PCB faulty.	Safety drain cycle – Cycle stopped with door open	Off
E35	Water overflow (flooding)	Water fill solenoid faulty; leakage from pressure switch hydraulic circuit; pressure switch faulty; wiring faulty; PCB faulty.	Cycle blocked. Safety drain cycle. Drain pump always in operation (5 minutes on, 5 minutes Off etc.)	Off
E36	Fault in “sensing” circuit of anti-boiling pressure switch	PCB faulty.	Cycle blocked, door locked.	Off
E37	1st level sensing circuit faulty	PCB faulty.	Cycle blocked, door locked.	Off
E39	“HV” sensor of anti-overflow level faulty	PCB faulty.	Cycle blocked, door locked.	Off
E41	Door open	Door interlock faulty; wiring faulty; PCB faulty.	Cycle paused	Start
E42	Problems of door closure	Door interlock faulty; wiring faulty; PCB faulty.	Cycle paused	Start
E43	Interlock power supply triac faulty	Door interlock faulty; wiring faulty; PCB faulty.	(Safety drain cycle) Cycle blocked	Off
E44	Door interlock sensor faulty	PCB faulty.	(Safety drain cycle) Cycle blocked	Off
E45	Door interlock sensing circuit triac faulty	PCB faulty.	(Safety drain cycle) Cycle blocked	Off
E51	Motor power supply triac short-circuited	PCB faulty; current leakage from motor or from wiring.	Cycle blocked, door locked (after 5 attempts)	Off
E52	No signal from motor tachymetric generator	Motor faulty; wiring faulty; PCB faulty.	Cycle blocked, door locked (after 5 attempts)	Off
E53	Motor triac sensing circuit faulty	PCB faulty.	Cycle blocked, door locked	Off
E54	Motor relay contacts sticking	PCB faulty; current leakage from motor or from wiring.	Cycle blocked, door locked (after 5 attempts)	Off

Alarm	Description	Possible fault	Action/machine status	Reset
E61	Insufficient heating during washing	NTC sensor faulty; heating element faulty; wiring faulty; PCB faulty.	The heating phase is skipped	—
E62	Overheating during washing	NTC sensor faulty; heating element faulty; wiring faulty; PCB faulty.	Safety drain cycle – Cycle stopped with door open	Off
E66	Heating element power relay faulty	PCB faulty; current leakage from heating element to ground.	Safety drain cycle – Cycle stopped with door open	Off
E71	Washing NTC sensor faulty	NTC sensor faulty; wiring faulty; PCB faulty.	The heating phase is skipped	Start
E74	Washing NTC-sensor badly positioned	NTC sensor badly positioned; NTC sensor faulty; wiring faulty; PCB faulty.	The heating phase is skipped	Start
E82	Error in selector reset position	PCB faulty.	—	Off
E83	Error in reading selector	Incorrect configuration data; PCB faulty.	Cycle cancelled	—
E91	Communication incongruence between main PCB- and display board (versions not compatible)	Wiring faulty; faulty control/display board; Main PCB faulty.	Cycle interrupted	Off
E92	Communication incongruence between main PCB- and display board (versions not compatible)	Wrong control/display board; Wrong PCB (does not correspond to the model).	Cycle interrupted	Off
E93	Incorrect configuration of appliance	Incorrect configuration data; PCB faulty.	Cycle interrupted	Off
E94	Incorrect configuration of washing cycle	Incorrect configuration data; PCB faulty.	Cycle interrupted	Off
E95	Communications error between microprocessor and EEPROM	PCB faulty.	Cycle interrupted	Off
E97	Incongruency between selector and cycles configuration	Incorrect configuration data; PCB faulty.	Cycle interrupted	Off
EB1	Frequency of appliance incorrect	Power supply problems (incorrect / disturbance); PCB faulty.	Cycle interrupted	—
EB2	Voltage too high	Power supply problems (incorrect / disturbance); PCB faulty.	Cycle interrupted	—
EB3	Voltage too low	Power supply problems (incorrect / disturbance); PCB faulty.	Cycle interrupted	—
EF1	Drain filter blocked (too long drain phase)	Drain tube blocked/kinked/too high; Drain filter dirty/blocked.	Warning displayed at the end of cycle (specific LED)	Start
EF2	Overdosing of detergent (too much foam during drain phases)	Excessive detergent dosing; drain tube kinked/blocked; Drain filter dirty/blocked.	(specific LED)	—
EF3	Control water intervention	Water leakage on the base; faulty water control device.	Water drain and cycle blocked	Off

## 11. Demo-mode

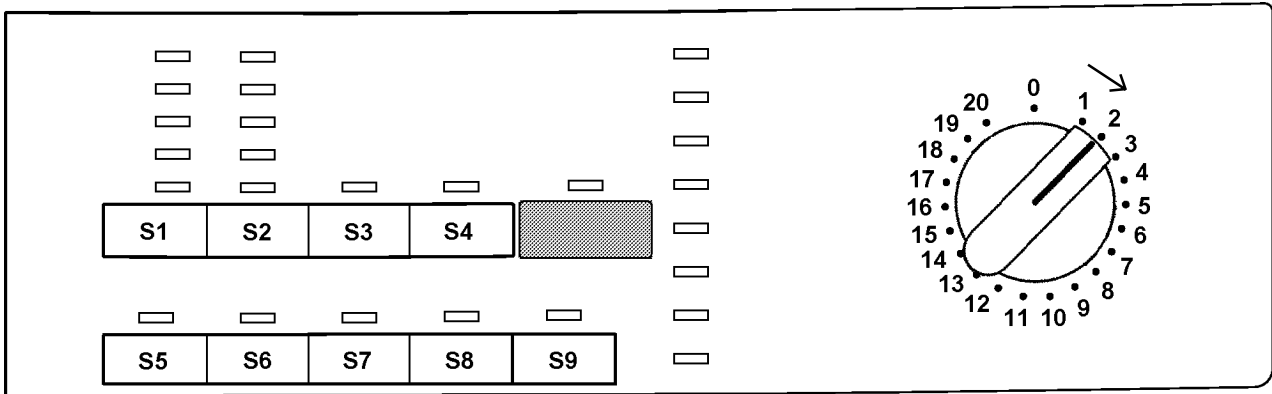

### 11.1 Access to demo-mode

- Switch off the appliance (programme selector position 0).
- Press and hold down **button S1 and S5** or **button S2 and S6** simultaneously.
- Holding down both buttons, switch the appliance on by turning the programme selector **two positions to the right** (clockwise).
- Continue to hold down both buttons at least 2 sec.

### 11.2 Exiting demo-mode

- To exit demo-mode, switch off the appliance.

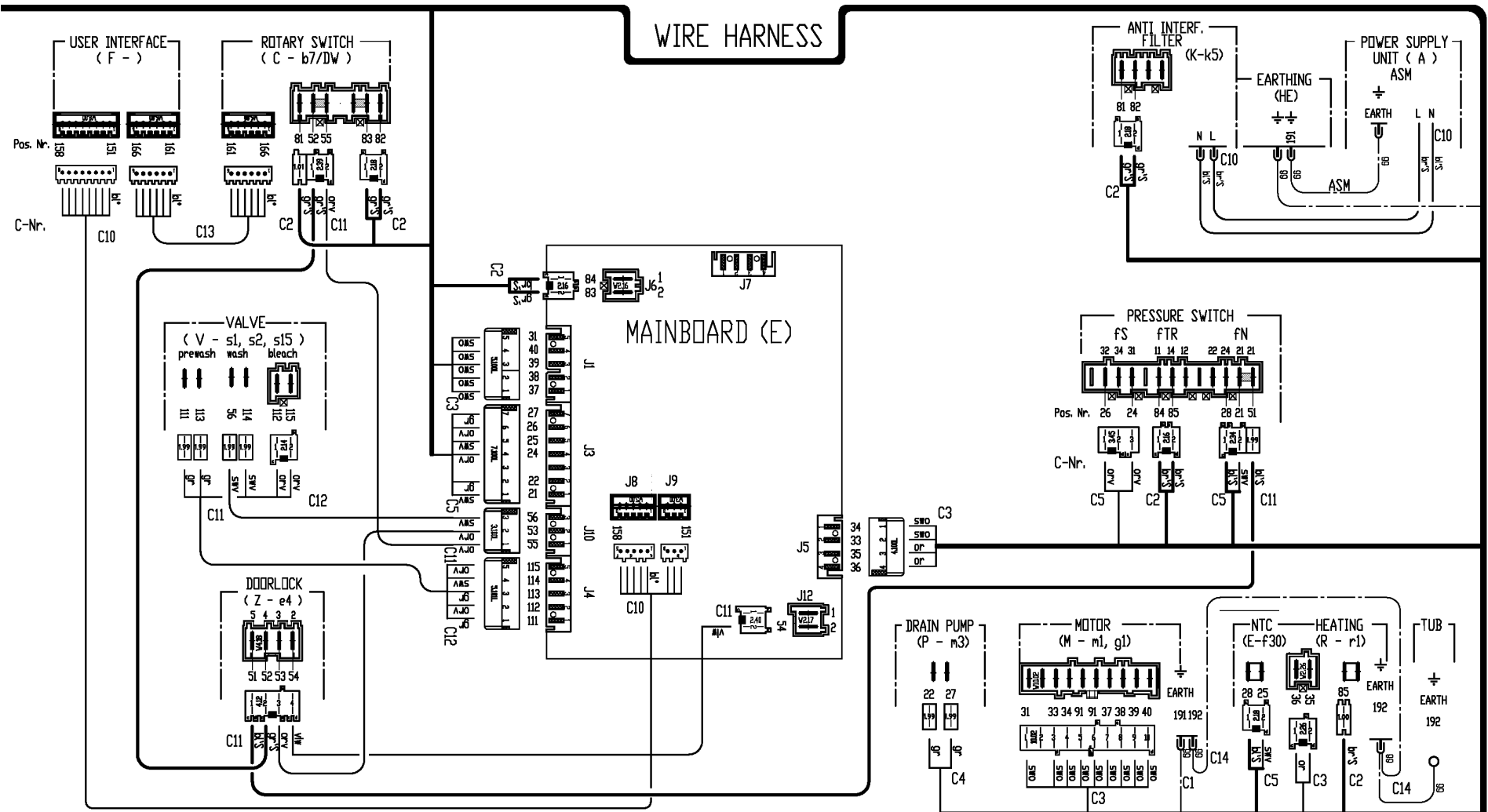

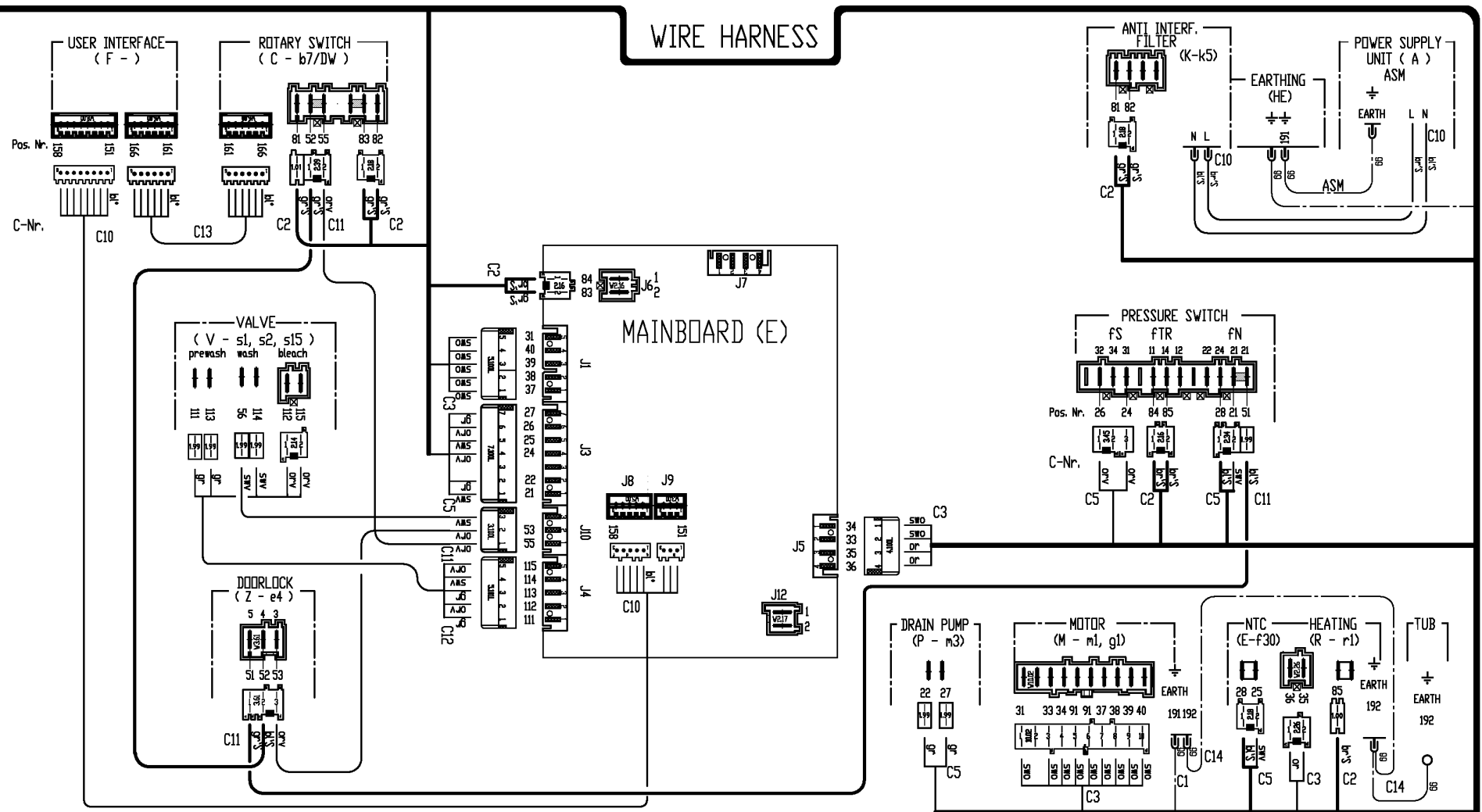

# 14. Circuit diagram Example with IDOLO-doorlock

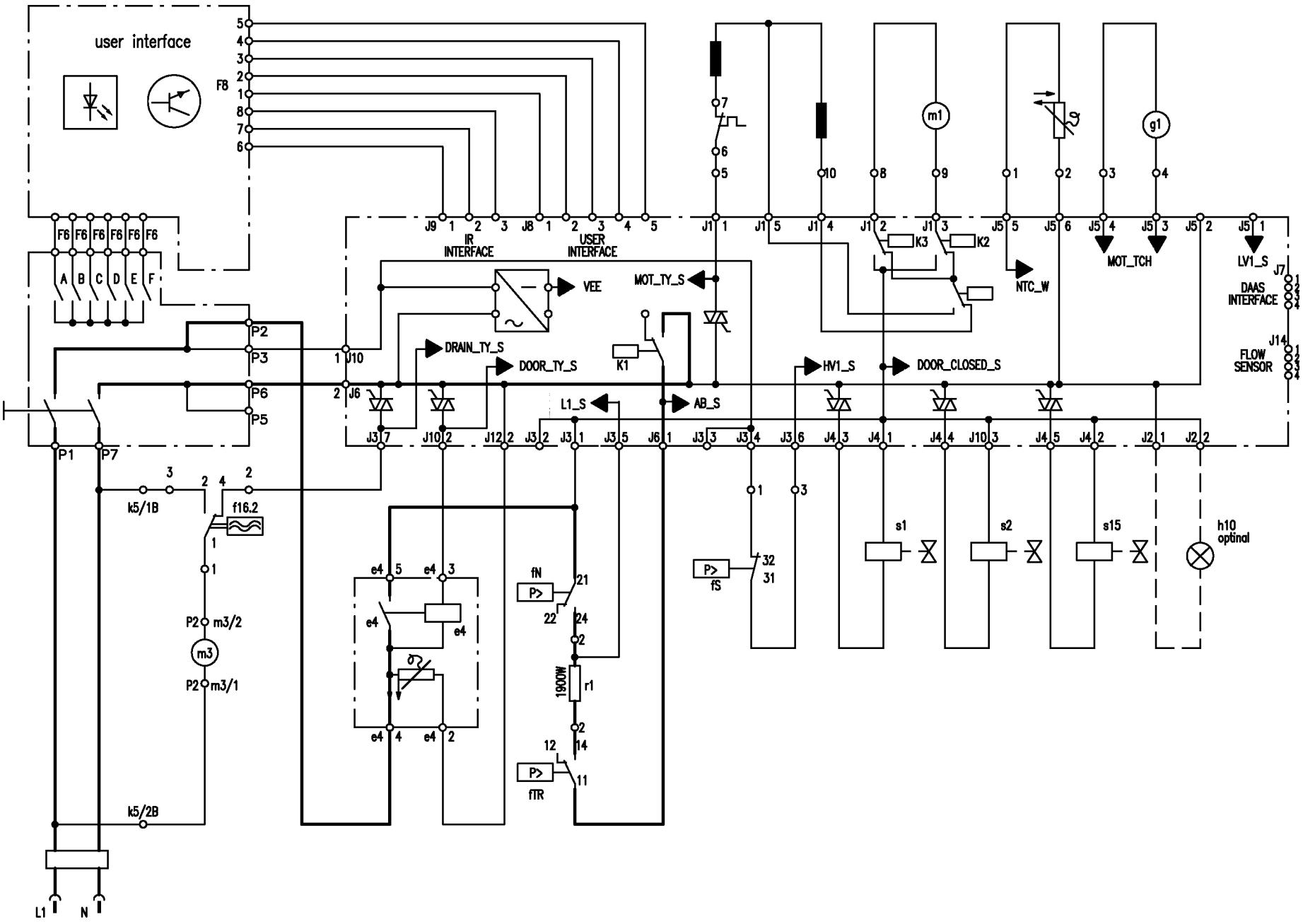



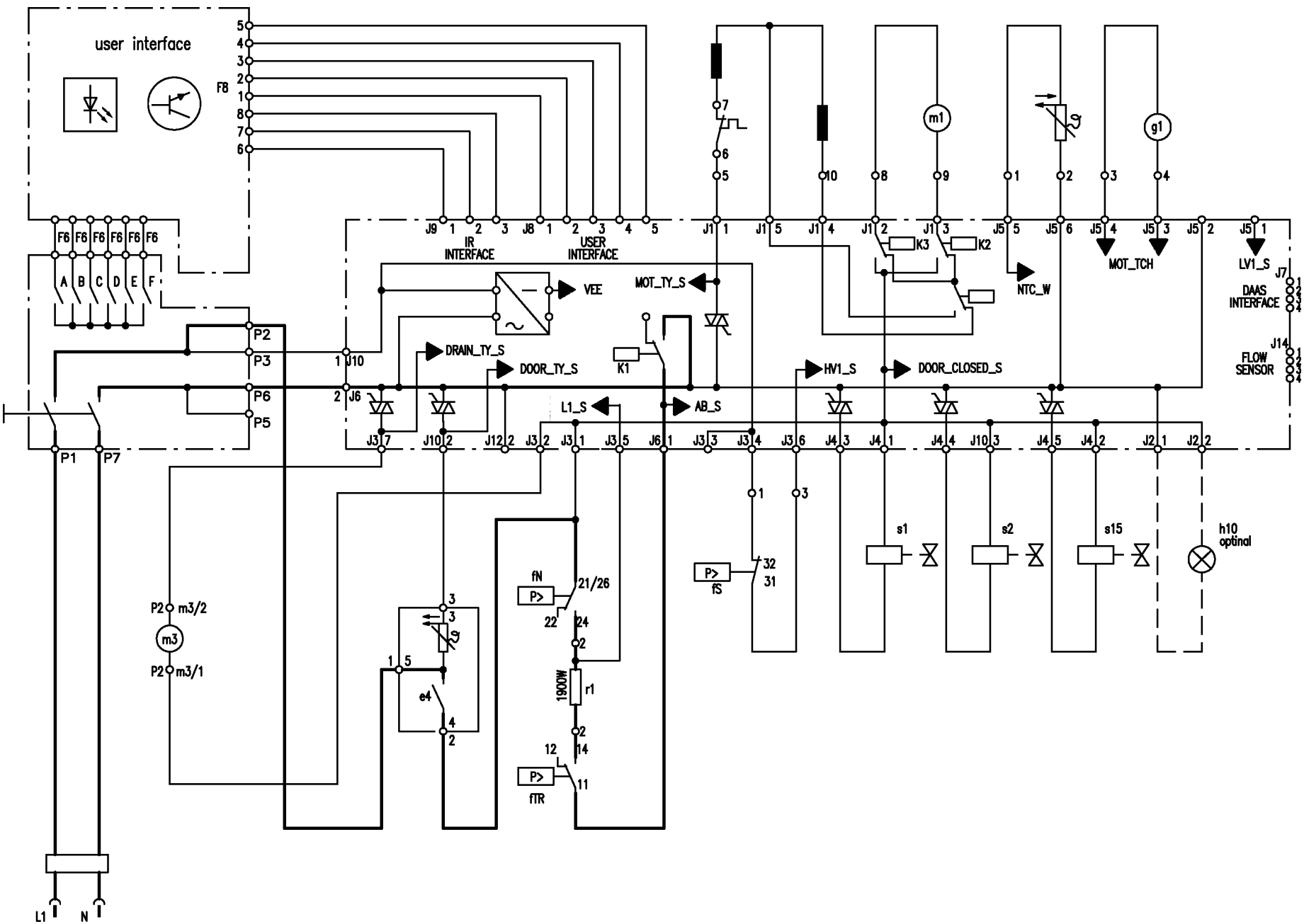

## 15. Legend

A	(ASM)	Connection housing
E	(f30)	NTC-sensor
HE		Main earth
K	(k5)	Suppressor
M	(m1/g1)	Motor
N	(fTr, fN, fH)	Pressure switch
P	(m3)	Pump
R	(r1)	Heating
V	(s1, s2)	Valve
Z	(e4)	Door lock